

REVISIONS			
LTR	DESCRIPTION	DATE (YR-MO-DA)	APPROVED
A	Changes in accordance with NOR 5962-R189-97. - cfs	97-02-24	Monica L. Poelking
B	Changes in accordance with NOR 5962-R416-97. - Itg	97-08-14	Monica L. Poelking
C	Update boilerplate and appendix A. Editorial changes throughout. - tmh	00-05-25	Monica L. Poelking
D	Update the boilerplate paragraphs to current requirements as specified in MIL-PRF-38535. Update section 1.5, Radiation features. Change title to correctly reflect the device function. – jak	09-06-15	Thomas M. Hess

REV																				
SHEET																				
REV	D	D	D	D	D	D														
SHEET	15	16	17	18	19	20														
REV STATUS	REV			D	D	D	D	D	D	D	D	D	D	D	D	D	D	D	D	
OF SHEETS	SHEET			1	2	3	4	5	6	7	8	9	10	11	12	13	14	14		
PMIC N/A	PREPARED BY Dan Wonnell						DEFENSE SUPPLY CENTER COLUMBUS COLUMBUS, OHIO 43218-3990 http://www.dsc.dla.mil													
STANDARD MICROCIRCUIT DRAWING THIS DRAWING IS AVAILABLE FOR USE BY ALL DEPARTMENTS AND AGENCIES OF THE DEPARTMENT OF DEFENSE AMSC N/A	CHECKED BY Monica L. Poelking																			
	APPROVED BY Monica L. Poelking																			
	DRAWING APPROVAL DATE 95-12-04																			
	REVISION LEVEL D																			
						SIZE A	CAGE CODE 67268	5962-96673												
						SHEET 1 OF 20														

1. SCOPE

1.1 Scope. This drawing documents two product assurance class levels consisting of high reliability (device classes Q and M) and space application (device class V). A choice of case outlines and lead finishes are available and are reflected in the Part or Identifying Number (PIN). When available, a choice of Radiation Hardness Assurance (RHA) levels is reflected in the PIN.

1.2 PIN. The PIN is as shown in the following example:

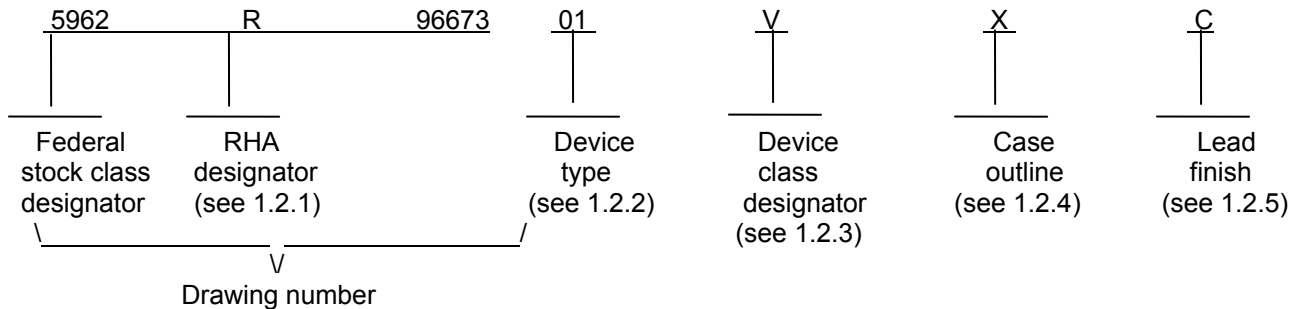

1.2.1 RHA designator. Device classes Q and V RHA marked devices meet the MIL-PRF-38535 specified RHA levels and are marked with the appropriate RHA designator. Device class M RHA marked devices meet the MIL-PRF-38535, appendix A specified RHA levels and are marked with the appropriate RHA designator. A dash (-) indicates a non-RHA device.

1.2.2 Device type(s). The device type(s) identify the circuit function as follows:

<u>Device type</u>	<u>Generic number</u>	<u>Circuit function</u>
01	4555B	Radiation hardened CMOS dual binary to 1 of 4 decoder/demultiplexers, outputs high on select
02	4556B	Radiation hardened CMOS dual binary to 1 of 4 decoder/demultiplexers, outputs low on select
03	4555BN	Radiation hardened CMOS dual binary to 1 of 4 decoder/demultiplexers, outputs high on select, with neutron irradiated die
04	4556BN	Radiation hardened CMOS dual binary to 1 of 4 decoder/demultiplexers, outputs low on select, with neutron irradiated die

1.2.3 Device class designator. The device class designator is a single letter identifying the product assurance level as follows:

<u>Device class</u>	<u>Device requirements documentation</u>
M	Vendor self-certification to the requirements for MIL-STD-883 compliant, non-JAN class level B microcircuits in accordance with MIL-PRF-38535, appendix A
Q or V	Certification and qualification to MIL-PRF-38535

1.2.4 Case outline(s). The case outline(s) are as designated in MIL-STD-1835 and as follows:

<u>Outline letter</u>	<u>Descriptive designator</u>	<u>Terminals</u>	<u>Package style</u>
E	CDIP2-T16	16	Dual-in-line package
X	CDFP4-F16	16	Flat package

1.2.5 Lead finish. The lead finish is as specified in MIL-PRF-38535 for device classes Q and V or MIL-PRF-38535, appendix A for device class M.

STANDARD MICROCIRCUIT DRAWING DEFENSE SUPPLY CENTER COLUMBUS COLUMBUS, OHIO 43218-3990	SIZE A		5962-96673
		REVISION LEVEL D	SHEET 2

1.3 Absolute maximum ratings. 1/ 2/ 3/

Supply voltage range (V_{DD}).....	-0.5 V dc to +20 V dc
Input voltage range	-0.5 V dc to $V_{DD} + 0.5$ V dc
DC input current, any one input.....	± 10 mA
Device dissipation per output transistor.....	100 mW
Storage temperature range (T_{STG}).....	-65°C to +150°C
Lead temperature (soldering, 10 seconds).....	+265°C
Thermal resistance, junction-to-case (θ_{JC}):	
Case E.....	24°C/W
Case X.....	29°C/W
Thermal resistance, junction-to-ambient (θ_{JA}):	
Case E.....	73°C/W
Case X.....	114°C/W
Junction temperature (T_J).....	+175°C
Maximum power dissipation at $T_A = +125^\circ\text{C}$ (P_D): 4/	
Case E.....	0.68 W
Case X.....	0.44 W

1.4 Recommended operating conditions.

Supply voltage range (V_{DD}).....	3.0 V dc to +18 V dc
Case operating temperature range (T_C).....	-55°C to +125°C
Input voltage (V_{IN}).....	0 V to V_{DD}
Output voltage (V_{OUT}).....	0 V to V_{DD}

1.5 Radiation features:

Maximum total dose available (dose rate = 50 – 300 rads (Si)/s)	1×10^5 Rads (Si)
Single event phenomenon (SEP) effective	
linear energy threshold, no upsets or latchup (see 4.4.4.5).....	≥ 75 MeV/(cm^2/mg) 5/
Dose rate upset (20 ns pulse).....	$\geq 5 \times 10^8$ Rads(Si)/s 5/
Dose rate latch-up	$\geq 2 \times 10^8$ Rads(Si)/s 5/
Dose rate survivability	$\geq 5 \times 10^{11}$ Rads(Si)/s 5/
Neutron irradiated (device types 03 and 04)	$\geq 1 \times 10^{14}$ neutrons/ cm^2

- 1/ Stresses above the absolute maximum rating may cause permanent damage to the device. Extended operation at the maximum levels may degrade performance and affect reliability.
- 2/ Unless otherwise specified, all voltages are referenced to V_{SS} .
- 3/ The limits for the parameters specified herein shall apply over the full specified V_{CC} range and case temperature range of -55°C to +125°C unless otherwise noted.
- 4/ If device power exceeds package dissipation capability, provide heat sinking or derate linearly (the derating is based on θ_{JA}) at the following rate:
 Case E..... 13.7 mW/°C
 Case X..... 8.8 mW/°C
- 5/ Limits are guaranteed by design or process, but not production tested unless specified by the customer through the purchase order or contract.

STANDARD MICROCIRCUIT DRAWING DEFENSE SUPPLY CENTER COLUMBUS COLUMBUS, OHIO 43218-3990	SIZE A		5962-96673
		REVISION LEVEL D	SHEET 3

2. APPLICABLE DOCUMENTS

2.1 Government specification, standards, and handbooks. The following specification, standards, and handbooks form a part of this drawing to the extent specified herein. Unless otherwise specified, the issues of these documents are those cited in the solicitation or contract.

DEPARTMENT OF DEFENSE SPECIFICATION

MIL-PRF-38535 - Integrated Circuits Manufacturing, General Specification for.

DEPARTMENT OF DEFENSE STANDARDS

MIL-STD-883 - Test Method Standard Microcircuits.
MIL-STD-1835 - Interface Standard Electronic Component Case Outlines.

DEPARTMENT OF DEFENSE HANDBOOKS

MIL-HDBK-103 - List of Standard Microcircuit Drawings.
MIL-HDBK-780 - Standard Microcircuit Drawings.

(Copies of these documents are available online at <http://assist.daps.dla.mil/quicksearch/> or from the Standardization Document Order Desk, 700 Robbins Avenue, Building 4D, Philadelphia, PA 19111-5094.)

2.2 Non-Government publications. The following document(s) form a part of this document to the extent specified herein. Unless otherwise specified, the issues of these documents are those cited in the solicitation or contract.

AMERICAN SOCIETY FOR TESTING AND MATERIALS (ASTM)

ASTM F1192 - Standard Guide for the Measurement of Single Event Phenomena (SEP) Induced by Heavy Ion Irradiation of semiconductor Devices.

(Copies of these documents are available online at <http://www.astm.org> or from ASTM International, 100 Barr Harbor Drive, P.O. Box C700, West Conshohocken, PA, 19428-2959).

2.2 Order of precedence. In the event of a conflict between the text of this drawing and the references cited herein, the text of this drawing takes precedence. Nothing in this document, however, supersedes applicable laws and regulations unless a specific exemption has been obtained.

3. REQUIREMENTS

3.1 Item requirements. The individual item requirements for device classes Q and V shall be in accordance with MIL-PRF-38535 and as specified herein or as modified in the device manufacturer's Quality Management (QM) plan. The modification in the QM plan shall not affect the form, fit, or function as described herein. The individual item requirements for device class M shall be in accordance with MIL-PRF-38535, appendix A for non-JAN class level B devices and as specified herein.

3.1.1 Microcircuit die. For the requirements for microcircuit die, see appendix A to the document.

3.2 Design, construction, and physical dimensions. The design, construction, and physical dimensions shall be as specified in MIL-PRF-38535 and herein for device classes Q and V or MIL-PRF-38535, appendix A and herein for device class M.

3.2.1 Case outlines. The case outlines shall be in accordance with 1.2.4 herein.

3.2.2 Terminal connections. The terminal connections shall be as specified on figure 1.

3.2.3 Truth tables. The truth tables shall be as specified on figure 2.

STANDARD MICROCIRCUIT DRAWING DEFENSE SUPPLY CENTER COLUMBUS COLUMBUS, OHIO 43218-3990	SIZE A		5962-96673
		REVISION LEVEL D	SHEET 4

3.2.6 Radiation exposure circuit. The radiation exposure circuit shall be maintained by the manufacturer under document revision level control and shall be made available to the preparing and acquiring activity upon request.

3.3 Electrical performance characteristics and postirradiation parameter limits. Unless otherwise specified herein, the electrical performance characteristics and postirradiation parameter limits are as specified in table I and shall apply over the full case operating temperature range.

3.4 Electrical test requirements. The electrical test requirements shall be the subgroups specified in table IIA. The electrical tests for each subgroup are defined in table I.

3.5 Marking. The part shall be marked with the PIN listed in 1.2 herein. In addition, the manufacturer's PIN may also be marked. For packages where marking of the entire SMD PIN number is not feasible due to space limitations, the manufacturer has the option of not marking the "5962-" on the device. For RHA product using this option, the RHA designator shall still be marked. Marking for device classes Q and V shall be in accordance with MIL-PRF-38535. Marking for device class M shall be in accordance with MIL-PRF-38535, appendix A.

3.5.1 Certification/compliance mark. The certification mark for device classes Q and V shall be a "QML" or "Q" as required in MIL-PRF-38535. The compliance mark for device class M shall be a "C" as required in MIL-PRF-38535, appendix A.

3.6 Certificate of compliance. For device classes Q and V, a certificate of compliance shall be required from a QML-38535 listed manufacturer in order to supply to the requirements of this drawing (see 6.6.1 herein). For device class M, a certificate of compliance shall be required from a manufacturer in order to be listed as an approved source of supply in MIL-HDBK-103 (see 6.6.2 herein). The certificate of compliance submitted to DSCC-VA prior to listing as an approved source of supply for this drawing shall affirm that the manufacturer's product meets, for device classes Q and V, the requirements of MIL-PRF-38535 and herein or for device class M, the requirements of MIL-PRF-38535, appendix A and herein.

3.7 Certificate of conformance. A certificate of conformance as required for device classes Q and V in MIL-PRF-38535 or for device class M in MIL-PRF-38535, appendix A shall be provided with each lot of microcircuits delivered to this drawing.

3.8 Notification of change for device class M. For device class M, notification to DSCC-VA of change of product (see 6.2 herein) involving devices acquired to this drawing is required for any change that affects this drawing.

3.9 Verification and review for device class M. For device class M, DSCC, DSCC's agent, and the acquiring activity retain the option to review the manufacturer's facility and applicable required documentation. Offshore documentation shall be made available onshore at the option of the reviewer.

3.10 Microcircuit group assignment for device class M. Device class M devices covered by this drawing shall be in microcircuit group number 39 (see MIL-PRF-38535, appendix A).

STANDARD MICROCIRCUIT DRAWING DEFENSE SUPPLY CENTER COLUMBUS COLUMBUS, OHIO 43218-3990	SIZE A		5962-96673
		REVISION LEVEL D	SHEET 5

TABLE I. Electrical performance characteristics.

Test	Symbol	Conditions -55°C ≤ T _C ≤ +125°C unless otherwise specified	Device type	Group A subgroups	Limits		Units		
					Min	Max			
Supply current	I _{DD}	V _{DD} = 20 V, V _{IN} = V _{DD} or GND	All	1		10	μA		
					M, D, P, L, R <u>2/</u>			1000	
		V _{DD} = 18 V, V _{IN} = V _{DD} or GND		1				25	
				V _{DD} = 5 V, V _{IN} = V _{DD} or GND <u>1/</u>	3			10	
		V _{DD} = 10 V, V _{IN} = V _{DD} or GND <u>1/</u>			1, 3			5	
				V _{DD} = 15 V, V _{IN} = V _{DD} or GND <u>1/</u>	2			150	
					1, 3			10	
					2			300	
					1, 3			10	
	2			600					
	Input leakage current low	I _{IL}	V _{DD} = 20 V, V _{IN} = V _{DD} or GND	All	1	-100		nA	
2					-1000				
3					-100				
Input leakage current high	I _{IH}	V _{DD} = 20 V, V _{IN} = V _{DD} or GND	All	1		100	nA		
				2		1000			
				3		100			
Output voltage, low	V _{OL}	V _{DD} = 15 V, no load	All	1, 2, 3		50	mV		
					V _{DD} = 5 V, no load <u>1/</u>			50	
					V _{DD} = 10 V, no load <u>1/</u>			50	
Output voltage, high	V _{OH}	V _{DD} = 15 V, no load <u>3/</u>	All	1, 2, 3		14.95	V		
					V _{DD} = 5 V, no load <u>1/</u>			4.95	
					V _{DD} = 10 V, no load <u>1/</u>			9.95	
Low level output current (sink)	I _{OL}	V _{DD} = 5 V V _O = 0.4 V	All	1		0.53	mA		
					V _{DD} = 10 V V _O = 0.5 V	2 <u>1/</u>			0.36
								V _{DD} = 15 V V _O = 1.5 V	3 <u>1/</u>
				1					
						2 <u>1/</u>			
									3 <u>1/</u>
				1					
						2 <u>1/</u>			
									3 <u>1/</u>

See notes at end of table.

STANDARD MICROCIRCUIT DRAWING DEFENSE SUPPLY CENTER COLUMBUS COLUMBUS, OHIO 43218-3990	SIZE A		5962-96673
		REVISION LEVEL D	SHEET 6

TABLE I. Electrical performance characteristics - Continued.

Test	Symbol	Conditions -55°C ≤ T _C ≤ +125°C unless otherwise specified	Device type	Group A subgroups	Limits		Unit
					Min	Max	
High level output current (source)	I _{OH}	V _{DD} = 5 V V _{OUT} = 4.6 V	All	1		-0.53	mA
				2 <u>1/</u>		-0.36	
				3 <u>1/</u>		-0.64	
		V _{DD} = 5 V V _{OUT} = 2.5 V	All	1		-1.8	
				2 <u>1/</u>		-1.15	
				3 <u>1/</u>		-2.0	
		V _{DD} = 10 V V _{OUT} = 9.5 V	All	1		-1.4	
				2 <u>1/</u>		-0.9	
				3 <u>1/</u>		-1.6	
		V _{DD} = 15 V V _{OUT} = 13.5 V	All	1		-3.5	
				2 <u>1/</u>		-2.4	
				3 <u>1/</u>		-4.2	
Input voltage	V _{IL}	V _{DD} = 5 V V _{OH} > 4.5 V, V _{OL} < 0.5 V	All	1, 2, 3		1.5	V
		V _{DD} = 10 V V _{OH} > 9.0 V, V _{OL} < 1.0 V <u>1/</u>		1, 2, 3		3	
		V _{DD} = 15 V V _{OH} > 13.5 V, V _{OL} < 1.5 V		1, 2, 3		4	
	V _{IH}	V _{DD} = 5 V V _{OH} > 4.5 V, V _{OL} < 0.5 V	All	1, 2, 3	3.5		
		V _{DD} = 10 V V _{OH} > 9.0 V, V _{OL} < 1.0 V <u>1/</u>		1, 2, 3	7		
		V _{DD} = 15 V V _{OH} > 13.5 V, V _{OL} < 1.5 V		1, 2, 3	11		
N threshold voltage	V _{NTH}	V _{DD} = 10 V, I _{SS} = -10 μA	All	1	-0.7	-2.8	V
N threshold voltage, delta	ΔV _{NTH}	V _{DD} = 10 V, I _{SS} = -10 μA, M, D, L, R <u>2/</u>	All	1		±1.0	
P threshold voltage	V _{PTH}	V _{SS} = 0.0 V, I _{DD} = 10 μA	All	1	0.7	2.8	
P threshold voltage, delta	ΔV _{PTH}	V _{SS} = 0.0 V, I _{DD} = 10 μA	All	1		±1.0	

See notes at end of table.

STANDARD MICROCIRCUIT DRAWING DEFENSE SUPPLY CENTER COLUMBUS COLUMBUS, OHIO 43218-3990	SIZE A		5962-96673
		REVISION LEVEL D	SHEET 7

TABLE I. Electrical performance characteristics - Continued.

Test	Symbol	Conditions -55°C ≤ T _C ≤ +125°C unless otherwise specified	Device type	Group A subgroups	Limits		Unit
					Min	Max	
Functional tests		V _{DD} = 2.8 V, V _{IN} = V _{DD} or GND	All	7	V _{OH} > V _{DD} /2	V _{OL} < V _{DD} /2	V
		V _{DD} = 20 V, V _{IN} = V _{DD} or GND		7			
		V _{DD} = 18 V, V _{IN} = V _{DD} or GND	All	8A			
		M, D, P, L, R <u>2/</u>		7			
		V _{DD} = 3.0 V, V _{IN} = V _{DD} or GND	All	8B			
		M, D, P, L, R <u>2/</u>		7			
Input capacitance	C _{IN}	Any input, See 4.4.1c <u>1/</u>	All	4		7.5	pF
Propagation delay time, A or B input to any output	t _{PHL1} , t _{PLH1}	V _{DD} = 5 V, V _{IN} = V _{DD} or GND <u>4/</u>	All	9		440	ns
				10, 11		594	
		M, D, P, L, R <u>2/</u>		9		594	
		V _{DD} = 10 V <u>1/</u> , <u>4/</u>		9		190	
		V _{DD} = 15 V <u>1/</u> , <u>4/</u>		9		140	
Propagation delay time, E to any output	t _{PHL2} , t _{PLH2}	V _{DD} = 5 V, V _{IN} = V _{DD} or GND <u>4/</u>	All	9		400	ns
				10, 11		540	
		M, D, P, L, R <u>2/</u>		9		540	
		V _{DD} = 10 V <u>1/</u> , <u>4/</u>		9		170	
		V _{DD} = 15 V <u>1/</u> , <u>4/</u>		9		130	
Transition time	t _{THL} , t _{TLH}	V _{DD} = 5 V, V _{IN} = V _{DD} or GND <u>4/</u>	All	9		200	ns
				10, 11		270	
		V _{DD} = 10 V <u>1/</u> , <u>4/</u>		9		100	
		V _{DD} = 15 V <u>1/</u> , <u>4/</u>		9		80	

1/ These tests are controlled via design or process and are not directly tested. These parameters are characterized on initial design release and upon design changes which affect these characteristics.

2/ Devices supplied to this drawing will meet all levels M, D, P, L, and R of irradiation. However, this device is only tested at the 'R' level. When performing post irradiation electrical measurements for any RHA level, T_A = +25°C. Pre and post irradiation values are identical unless otherwise specified in table IA.

3/ For accuracy, voltage is measured differentially to V_{DD}. Limit is 0.050 V Max.

4/ C_L = 50 pF, R_L = 200 kΩ, Input t_R, t_F < 20 ns.

STANDARD MICROCIRCUIT DRAWING DEFENSE SUPPLY CENTER COLUMBUS COLUMBUS, OHIO 43218-3990	SIZE A		5962-96673
		REVISION LEVEL D	SHEET 8

Device type	01, 03	02, 04
Case outlines	E and X	
Terminal number	Terminal symbol	
1	\overline{E}_1	\overline{E}_1
2	A ₁	A ₁
3	B ₁	B ₁
4	Q0 ₁	$\overline{Q0}_1$
5	Q1 ₁	$\overline{Q1}_1$
6	Q2 ₁	$\overline{Q2}_1$
7	Q3 ₁	$\overline{Q3}_1$
8	V _{SS}	V _{SS}
9	Q3 ₂	$\overline{Q3}_2$
10	Q2 ₂	$\overline{Q2}_2$
11	Q1 ₂	$\overline{Q1}_2$
12	Q0 ₂	$\overline{Q0}_2$
13	B ₂	B ₂
14	A ₂	A ₂
15	E ₂	E ₂
16	V _{DD}	V _{DD}

FIGURE 1. Terminal connections.

INPUTS ENABLE SELECT			OUTPUTS DEVICE TYPES 01, 03				OUTPUTS DEVICE TYPES 02, 04			
\overline{E}	B	A	Q3 _x	Q2 _x	Q1 _x	Q0 _x	$\overline{Q3}_x$	$\overline{Q2}_x$	$\overline{Q1}_x$	$\overline{Q0}_x$
0	0	0	0	0	0	1	1	1	1	0
0	0	1	0	0	1	0	1	1	0	1
0	1	0	0	1	0	0	1	0	1	1
0	1	1	1	0	0	0	0	1	1	1
1	X	X	0	0	0	0	1	1	1	1

Notes: 0 = low level
1 = high level
X = don't care

FIGURE 2. Truth table.

STANDARD MICROCIRCUIT DRAWING DEFENSE SUPPLY CENTER COLUMBUS COLUMBUS, OHIO 43218-3990	SIZE A		5962-96673
		REVISION LEVEL D	SHEET 9

4.4.1 Group A inspection.

- a. Tests shall be as specified in table IIA herein.
- b. For device class M, subgroups 7 and 8 tests shall be sufficient to verify the truth table. For device classes Q and V, subgroups 7 and 8 shall include verifying the functionality of the device; these tests shall have been fault graded in accordance with MIL-STD-883, method 5012 (see 1.5 herein).
- c. Subgroup 4 (C_{IN} measurement) shall be measured only for the initial qualification and after process or design changes which may affect capacitance. C_{IN} shall be measured between the designated terminal and GND at a frequency of 1 MHz. Tests shall be sufficient to validate the limits defined in table I herein.

TABLE IIA. Electrical test requirements.

Test requirements	Subgroups (in accordance with MIL-STD-883, method 5005, table I)	Subgroups (in accordance with MIL-PRF-38535, table III)	
	Device class M	Device class Q	Device class V
Interim electrical parameters (see 4.2)	1, 7, 9	1, 7, 9	1, 7, 9
Final electrical parameters (see 4.2)	1/ 1, 2, 3, 7, 8, 9, 10, 11	1/ 1, 2, 3, 7, 8, 9, 10, 11	2/ 3/ 1, 2, 3, 7, 8, 9, 10, 11
Group A test requirements (see 4.4)	1, 2, 3, 4, 7, 8, 9, 10, 11	1, 2, 3, 4, 7, 8, 9, 10, 11	1, 2, 3, 4, 7, 8, 9, 10, 11
Group C end-point electrical parameters (see 4.4)	1, 2, 3, 7, 8, 9, 10, 11	1, 2, 3, 7, 8, 9, 10, 11	3/ 1, 2, 3, 7, 8, 9, 10, 11
Group D end-point electrical parameters (see 4.4)	1, 7, 9	1, 7, 9	1, 7, 9
Group E end-point electrical parameters (see 4.4)	1, 7, 9	1, 7, 9	1, 7, 9

1/ PDA applies to subgroup 1 and 7.

2/ PDA applies to subgroups 1, 7, 9 and deltas.

3/ Delta limits as specified in table IIB shall be required where specified, and the delta limits shall be completed with reference to the zero hour electrical parameters (see Table I).

Table IIB. Burn-in and operating life test Delta parameters (+25°C)

Parameter	Symbol	Delta Limits
Supply current	I_{DD}	$\pm 1.0 \mu A$
Output current (sink) $V_{DD} = 5.0 V$	I_{OL}	$\pm 20\%$
Output current (source) $V_{DD} = 5.0 V, V_{OUT} = 4.6 V$	I_{OH}	$\pm 20\%$

4.4.2 Group C inspection. The group C inspection end-point electrical parameters shall be as specified in table IIA herein.

4.4.2.1 Additional criteria for device class M. Steady-state life test conditions, method 1005 of MIL-STD-883:

- a. Test condition A, B, C, or D. The test circuit shall be maintained by the manufacturer under document revision level control and shall be made available to the preparing or acquiring activity upon request. The test circuit shall specify the inputs, outputs, biases, and power dissipation, as applicable, in accordance with the intent specified in method 1005 of MIL-STD-883.
- b. $T_A = +125^\circ C$, minimum.
- c. Test duration: 1,000 hours, except as permitted by method 1005 of MIL-STD-883.

STANDARD MICROCIRCUIT DRAWING DEFENSE SUPPLY CENTER COLUMBUS COLUMBUS, OHIO 43218-3990	SIZE A		5962-96673
		REVISION LEVEL D	SHEET 10

4.4.2.2 Additional criteria for device classes Q and V. The steady-state life test duration, test condition and test temperature, or approved alternatives shall be as specified in the device manufacturer's QM plan in accordance with MIL-PRF-38535. The test circuit shall be maintained under document revision level control by the device manufacturer's TRB in accordance with MIL-PRF-38535 and shall be made available to the acquiring or preparing activity upon request. The test circuit shall specify the inputs, outputs, biases, and power dissipation, as applicable, in accordance with the intent specified in test method 1005 of MIL-STD-883.

4.4.3 Group D inspection. The group D inspection end-point electrical parameters shall be as specified in table IIA herein.

4.4.4 Group E inspection. Group E inspection is required only for parts intended to be marked as radiation hardness assured (see 3.5 herein). RHA levels for device classes M, Q and V shall be as specified in MIL-PRF-38535. End-point electrical parameters shall be as specified in table IIA herein.

4.4.4.1 Total dose irradiation testing. Total dose irradiation testing shall be performed in accordance with MIL-STD-883 method 1019, condition A, and as specified herein.

4.4.4.1.1 Accelerated annealing test. Accelerated annealing tests shall be performed on all devices requiring a RHA level greater than 5k rads(Si). The post-anneal end-point electrical parameter limits shall be as specified in table I herein and shall be the pre-irradiation end-point electrical parameter limit at +25°C ±5°C. Testing shall be performed at initial qualification and after any design or process changes which may affect the RHA response of the device.

4.4.4.2 Neutron irradiation. Neutron irradiation for device types 03 and 04 shall be conducted in wafer form using a neutron fluence of approximately 1×10^{14} neutrons/cm².

4.4.4.3 Dose rate induced latch-up testing. When required by the customer, dose rate induced latch-up testing shall be performed in accordance with method 1020 of MIL-STD-883 and as specified herein. Tests shall be performed on devices, SEC, or approved test structures at technology qualification and after any design or process changes which may affect the RHA capability of the process.

4.4.4.4 Dose rate upset testing. When required by the customer, dose rate upset testing shall be performed in accordance with method 1021 of MIL-STD-883 and herein.

- a. Transient dose rate upset testing for class M devices shall be performed at initial qualification and after any design or process changes which may affect the RHA performance of the devices. Test 10 devices with 0 defects unless otherwise specified.
- b. Transient dose rate upset testing for class Q and V devices shall be performed as specified by a TRB approved radiation hardness assurance plan and MIL-PRF-38535. Device parametric parameters that influence upset immunity shall be monitored at the wafer level in accordance with the wafer level hardness assurance plan and MIL-PRF-38535.

4.4.4.5 Single event phenomena (SEP). When specified in the purchase order or contract, SEP testing shall be performed on class V devices. SEP testing shall be performed on the Standard Evaluation Circuit (SEC) or alternate SEP test vehicle as approved by the qualifying activity at initial qualification and after any design or process changes which may affect the upset or latchup characteristics. Test four devices with zero failures. ASTM F1192 may be used as a guideline when performing SEP testing. The test conditions for SEP are as follows:

- a. The ion beam angle of incidence shall be between normal to the die surface and 60° to the normal, inclusive (i.e. $0^\circ \leq \text{angle} \leq 60^\circ$). No shadowing of the ion beam due to fixturing or package related effects is allowed.
- b. The fluence shall be ≥ 100 errors or $\geq 10^7$ ions/cm².
- c. The flux shall be between 10^2 and 10^5 ions/cm²/s. The cross-section shall be verified to be flux independent by measuring the cross-section at two flux rates which differ by at least an order of magnitude.
- d. The particle range shall be ≥ 20 microns in silicon.
- e. The upset test temperature shall be +25°C. The latchup test temperature shall be at the maximum rated operating temperature $\pm 10^\circ\text{C}$ for the latchup measurements.
- f. Bias conditions shall be defined by the manufacturer for latchup measurements.
- g. For SEP test limits, see table IB herein.

STANDARD MICROCIRCUIT DRAWING DEFENSE SUPPLY CENTER COLUMBUS COLUMBUS, OHIO 43218-3990	SIZE A		5962-96673
		REVISION LEVEL D	SHEET 11

4.5 Methods of inspection. Methods of inspection shall be as specified as follows:

4.5.1 Voltage and current. Unless otherwise specified, all voltages given are referenced to the microcircuit GND terminal. Currents given are conventional current and positive when flowing into the referenced terminal.

5. PACKAGING

5.1 Packaging requirements. The requirements for packaging shall be in accordance with MIL-PRF-38535 for device classes Q and V or MIL-PRF-38535, appendix A for device class M.

6. NOTES

6.1 Intended use. Microcircuits conforming to this drawing are intended for use for Government microcircuit applications (original equipment), design applications, and logistics purposes.

6.1.1 Replaceability. Microcircuits covered by this drawing will replace the same generic device covered by a contractor prepared specification or drawing.

6.1.2 Substitutability. Device class Q devices will replace device class M devices.

6.2 Configuration control of SMD's. All proposed changes to existing SMD's will be coordinated with the users of record for the individual documents. This coordination will be accomplished using DD Form 1692, Engineering Change Proposal.

6.3 Record of users. Military and industrial users should inform Defense Supply Center Columbus (DSCC) when a system application requires configuration control and which SMD's are applicable to that system. DSCC will maintain a record of users and this list will be used for coordination and distribution of changes to the drawings. Users of drawings covering microelectronic devices (FSC 5962) should contact DSCC-VA, telephone (614) 692-0544.

6.4 Comments. Comments on this drawing should be directed to DSCC-VA, Columbus, Ohio 43218-3990, or telephone (614) 692-0547.

6.5 Abbreviations, symbols, and definitions. The abbreviations, symbols, and definitions used herein are defined in MIL-PRF-38535 and MIL-HDBK-1331.

6.6 Sources of supply.

6.6.1 Sources of supply for device classes Q and V. Sources of supply for device classes Q and V are listed in QML-38535. The vendors listed in QML-38535 have submitted a certificate of compliance (see 3.6 herein) to DSCC-VA and have agreed to this drawing.

6.6.2 Approved sources of supply for device class M. Approved sources of supply for class M are listed in MIL-HDBK-103. The vendors listed in MIL-HDBK-103 have agreed to this drawing and a certificate of compliance (see 3.6 herein) has been submitted to and accepted by DSCC-VA.

6.7 Additional information. A copy of the following additional data shall be maintained and available from the device manufacturer:

- a. RHA upset levels.
- b. Test conditions (SEP).
- c. Number of upsets (SEP).
- d. Number of transients (SEP).
- e. Occurrence of latchup (SEP).

STANDARD MICROCIRCUIT DRAWING DEFENSE SUPPLY CENTER COLUMBUS COLUMBUS, OHIO 43218-3990	SIZE A		5962-96673
		REVISION LEVEL D	SHEET 12

APPENDIX A
APPENDIX A FORMS A PART OF SMD 5962-96673

A.1. SCOPE

A.1.1 Scope. This appendix establishes minimum requirements for microcircuit die to be supplied under the Qualified Manufacturers List (QML) Program. QML microcircuit die meeting the requirements of MIL-PRF-38535 and the manufacturers approved QM plan for use in monolithic microcircuits, multichip modules (MCMs), hybrids, electronic modules, or devices using chip and wire designs in accordance with MIL-PRF-38534 are specified herein. Two product assurance classes consisting of military high reliability (device class Q) and space application (device Class V) are reflected in the Part or Identification Number (PIN). When available a choice of Radiation Hardness Assurance (RHA) levels is reflected in the PIN.

A.1.2 PIN. The PIN shall be as shown in the following example:

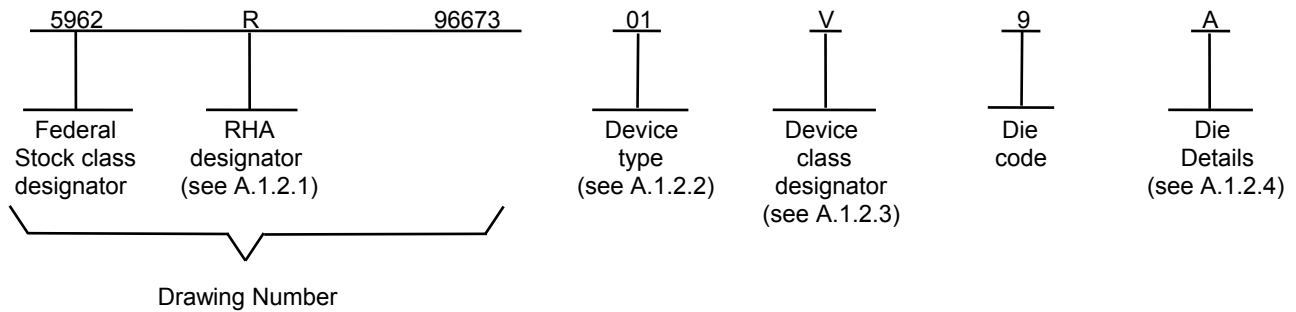

A.1.2.1 RHA designator. Device classes Q and V RHA identified die shall meet the MIL-PRF-38535 specified RHA levels. A dash (-) indicates a non-RHA die.

A.1.2.2 Device type(s). The device type(s) shall identify the circuit function as follows:

<u>Device type</u>	<u>Generic number</u>	<u>Circuit function</u>
01	4555B	Radiation hardened CMOS dual binary to 1 of 4 decoder/demultiplexers, outputs high on select
02	4556B	Radiation hardened CMOS dual binary to 1 of 4 decoder/demultiplexers, outputs low on select
03	4555BN	Radiation hardened CMOS dual binary to 1 of 4 decoder/demultiplexers, outputs high on select, with neutron irradiated die
04	4556BN	Radiation hardened CMOS dual binary to 1 of 4 decoder/demultiplexers, outputs low on select, with neutron irradiated die

A.1.2.3 Device class designator.

<u>Device class</u>	<u>Device requirements documentation</u>
Q or V	Certification and qualification to the die requirements of MIL-PRF-38535.

STANDARD MICROCIRCUIT DRAWING DEFENSE SUPPLY CENTER COLUMBUS COLUMBUS, OHIO 43218-3990	SIZE A		5962-96673
		REVISION LEVEL D	SHEET 13

APPENDIX A
APPENDIX A FORMS A PART OF SMD 5962-96673

A.1.2.4 Die Details. The die details designation shall be a unique letter which designates the die's physical dimensions, bonding pad location(s) and related electrical function(s), interface materials, and other assembly related information, for each product and variant supplied to this appendix.

A.1.2.4.1 Die Physical dimensions.

<u>Die Types</u>	<u>Figure number</u>
01, 03	A-1
02, 04	A-2

A.1.2.4.2 Die Bonding pad locations and Electrical functions.

<u>Die Types</u>	<u>Figure number</u>
01, 03	A-1
02, 04	A-2

A.1.2.4.3 Interface Materials.

<u>Die Types</u>	<u>Figure number</u>
01, 03	A-1
02, 04	A-2

A.1.2.4.4 Assembly related information.

01, 03	A-1
02, 04	A-2

A.1.3 Absolute maximum ratings. See paragraph 1.3 within the body of this drawing for details.

A.1.4 Recommended operating conditions. See paragraph 1.4 within the body of this drawing for details.

A.2. APPLICABLE DOCUMENTS

A.2.1 Government specifications, standards, and handbooks. The following specification, standards, and handbooks form a part of this drawing to the extent specified herein. Unless otherwise specified, the issues of these documents are those cited in the solicitation or contract.

DEPARTMENT OF DEFENSE SPECIFICATION

MIL-PRF-38535 - Integrated Circuits Manufacturing, General Specification for.

DEPARTMENT OF DEFENSE STANDARD

MIL-STD-883 - Test Method Standard Microcircuits.

DEPARTMENT OF DEFENSE HANDBOOKS

MIL-HDBK-103 - List of Standard Microcircuit Drawings.
MIL-HDBK-780 - Standard Microcircuit Drawings.

(Copies of these documents are available online at <http://assist.daps.dla.mil/quicksearch/> or from the Standardization Document Order Desk, 700 Robbins Avenue, Building 4D, Philadelphia, PA 19111-5094.)

STANDARD MICROCIRCUIT DRAWING DEFENSE SUPPLY CENTER COLUMBUS COLUMBUS, OHIO 43218-3990	SIZE A		5962-96673
		REVISION LEVEL D	SHEET 14

APPENDIX A
APPENDIX A FORMS A PART OF SMD 5962-96673

A.2.2 Order of precedence. In the event of a conflict between the text of this drawing and the references cited herein, the text of this drawing shall take precedence.

A.3 REQUIREMENTS

A.3.1 Item Requirements. The individual item requirements for device classes Q and V shall be in accordance with MIL-PRF-38535 and as specified herein or as modified in the device manufacturer's Quality Management (QM) plan. The modification in the QM plan shall not effect the form, fit or function as described herein.

A.3.2 Design, construction and physical dimensions. The design, construction and physical dimensions shall be as specified in MIL-PRF-38535 and the manufacturer's QM plan, for device classes Q and V and herein.

A.3.2.1 Die Physical dimensions. The die physical dimensions shall be as specified in A.1.2.4.1 and on figures A-1 and A-2.

A.3.2.2 Die bonding pad locations and electrical functions. The die bonding pad locations and electrical functions shall be as specified in A.1.2.4.2 and on figures A-1 and A-2.

A.3.2.3 Interface materials. The interface materials for the die shall be as specified in A.1.2.4.3 and on figures A-1 and A-2.

A.3.2.4 Assembly related information. The assembly related information shall be as specified in A.1.2.4.4 and figures A-1 and A-2.

A.3.2.5 Truth table(s). The truth table(s) shall be as defined within paragraph 3.2.3 of the body of this document.

A.3.2.6 Radiation exposure circuit. The radiation exposure circuit shall be as defined within paragraph 3.2.4 of the body of this document.

A.3.3 Electrical performance characteristics and post-irradiation parameter limits. Unless otherwise specified herein, the electrical performance characteristics and post-irradiation parameter limits are as specified in table I of the body of this document.

A.3.4 Electrical test requirements. The wafer probe test requirements shall include functional and parametric testing sufficient to make the packaged die capable of meeting the electrical performance requirements in table I.

A.3.5 Marking. As a minimum, each unique lot of die, loaded in single or multiple stack of carriers, for shipment to a customer, shall be identified with the wafer lot number, the certification mark, the manufacturer's identification and the PIN listed in A.1.2 herein. The certification mark shall be a "QM" or "Q" as required by MIL-PRF-38535.

A.3.6 Certification of compliance. For device classes Q and V, a certificate of compliance shall be required from a QML-38535 listed manufacturer in order to supply to the requirements of this drawing (see 60.4 herein). The certificate of compliance submitted to DSCC-VA prior to listing as an approved source of supply for this appendix shall affirm that the manufacturer's product meets, for device classes Q and V, the requirements of MIL-PRF-38535 and the requirements herein.

A.3.7 Certificate of conformance. A certificate of conformance as required for device classes Q and V in MIL-PRF-38535 shall be provided with each lot of microcircuit die delivered to this drawing.

A.4. VERIFICATION

A.4.1 Sampling and inspection. For device classes Q and V, die sampling and inspection procedures shall be in accordance with MIL-PRF-38535 or as modified in the device manufacturer's Quality Management (QM) plan. The modifications in the QM plan shall not effect the form, fit or function as described herein.

STANDARD MICROCIRCUIT DRAWING DEFENSE SUPPLY CENTER COLUMBUS COLUMBUS, OHIO 43218-3990	SIZE A		5962-96673
		REVISION LEVEL D	SHEET 15

APPENDIX A
APPENDIX A FORMS A PART OF SMD 5962-96673

A.4.2 Screening. For device classes Q and V, screening shall be in accordance with MIL-PRF-38535, and as defined in the manufacturer's QM plan. As a minimum it shall consist of:

- a) Wafer Lot acceptance for Class V product using the criteria defined within MIL-STD-883 TM 5007.
- b) 100% wafer probe (see paragraph A.3.4).
- c) 100% internal visual inspection to the applicable class Q or V criteria defined within MIL-STD-883 TM2010 or the alternate procedures allowed within MIL-STD-883 TM5004.

A.4.3 Conformance inspection.

A.4.3.1 Group E inspection. Group E inspection is required only for parts intended to be identified as radiation assured (see A.3.5 herein). RHA levels for device classes Q and V shall be as specified in MIL-PRF-38535. End point electrical testing of packaged die shall be as specified in table IIA herein. Group E tests and conditions are as specified within paragraphs 4.4.4.1, 4.4.4.1.1, 4.4.4.2, 4.4.4.3, 4.4.4.4 and 4.4.4.5.

A.5. DIE CARRIER

A.5.1 Die carrier requirements. The requirements for the die carrier shall be accordance with the manufacturer's QM plan or as specified in the purchase order by the acquiring activity. The die carrier shall provide adequate physical, mechanical and electrostatic protection.

A.6. NOTES

A.6.1 Intended use. Microcircuit die conforming to this drawing are intended for use in microcircuits built in accordance with MIL-PRF-38535 or MIL-PRF-38534 for government microcircuit applications (original equipment), design applications and logistics purposes.

A.6.2 Comments. Comments on this appendix should be directed to DSCC-VA, Columbus, Ohio, 43218-3990 or telephone (614)-692-0547.

A.6.3 Abbreviations, symbols and definitions. The abbreviations, symbols, and definitions used herein are defined with MIL-PRF-38535 and MIL-STD-1331.

A.6.4 Sources of Supply for device classes Q and V. Sources of supply for device classes Q and V are listed in QML-38535. The vendors listed within QML-38535 have submitted a certificate of compliance (see A.3.6 herein) to DSCC-VA and have agreed to this drawing.

STANDARD MICROCIRCUIT DRAWING DEFENSE SUPPLY CENTER COLUMBUS COLUMBUS, OHIO 43218-3990	SIZE A		5962-96673
		REVISION LEVEL D	SHEET 16

APPENDIX A
 APPENDIX A FORMS A PART OF SMD 5962-96673

o DIE PHYSICAL DIMENSIONS

Die Size: 1981 x 2083 microns.
 Die Thickness: 20 ±1 mils.

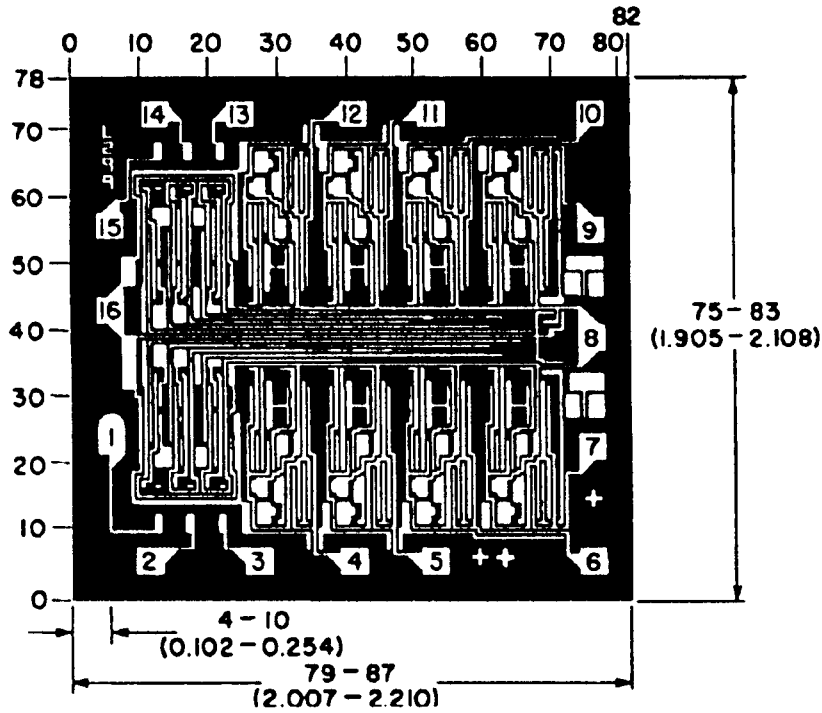

NOTE: Pad numbers reflect terminal numbers when placed in Case Outlines E, X (see Figure 1).

Figure A-1. Die bonding pad locations and electrical functions

STANDARD MICROCIRCUIT DRAWING DEFENSE SUPPLY CENTER COLUMBUS COLUMBUS, OHIO 43218-3990	SIZE A		5962-96673
		REVISION LEVEL D	SHEET 17

APPENDIX A
APPENDIX A FORMS A PART OF SMD 5962-96673

o INTERFACE MATERIALS

Top Metallization: Al 11.0kÅ - 14.0kÅ

Backside Metallization: None.

Glassivation
 Type: PSG
 Thickness: 10.4kÅ - 15.6kÅ

Substrate: Single crystal silicon.

o ASSEMBLY RELATED INFORMATION

Substrate Potential: Floating or tied to V_{DD} .

Special assembly instructions: Bond pad #16 (V_{DD}) first.

Figure A-1. Die bonding pad locations and electrical functions - Continued

STANDARD MICROCIRCUIT DRAWING DEFENSE SUPPLY CENTER COLUMBUS COLUMBUS, OHIO 43218-3990	SIZE A	5962-96673
	REVISION LEVEL D	SHEET 18

APPENDIX A
 APPENDIX A FORMS A PART OF SMD 5962-96673

o DIE PHYSICAL DIMENSIONS

Die Size: 1981 x 2083 microns.
 Die Thickness: 20 ±1 mils.

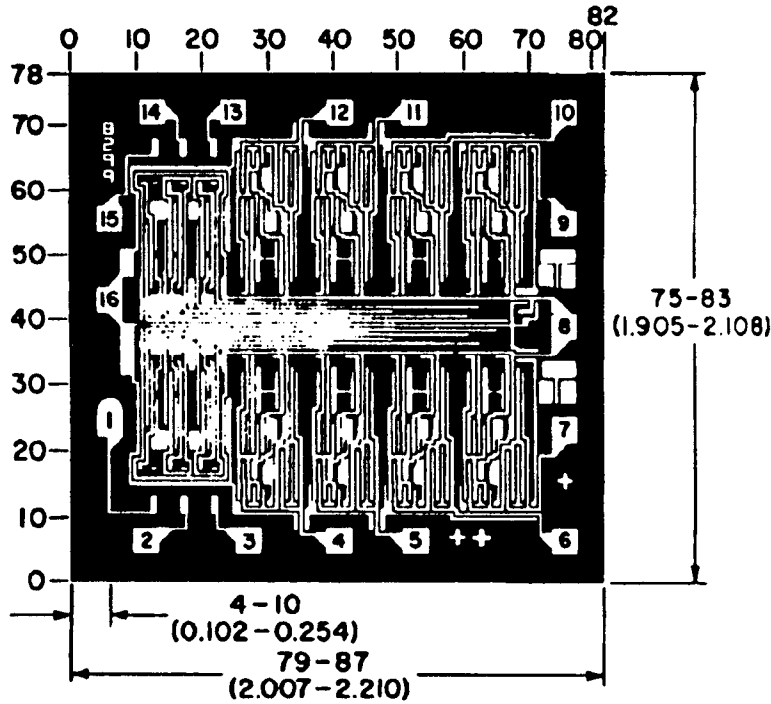

NOTE: Pad numbers reflect terminal numbers when placed in Case Outlines E, X (see Figure 1).

Figure A-2. Die bonding pad locations and electrical functions

STANDARD MICROCIRCUIT DRAWING DEFENSE SUPPLY CENTER COLUMBUS COLUMBUS, OHIO 43218-3990	SIZE A		5962-96673
		REVISION LEVEL D	SHEET 19

APPENDIX A
APPENDIX A FORMS A PART OF SMD 5962-96673

o INTERFACE MATERIALS

Top Metallization: Al 11.0kÅ - 14.0kÅ
 Backside Metallization: None.
 Glassivation
 Type: PSG
 Thickness: 10.4kÅ - 15.6kÅ
 Substrate: Single crystal silicon.

o ASSEMBLY RELATED INFORMATION

Substrate Potential: Floating or tied to V_{DD}.
 Special assembly instructions: Bond pad #16 (V_{DD}) first.

Figure A-2. Die bonding pad locations and electrical functions – Continued.

STANDARD MICROCIRCUIT DRAWING DEFENSE SUPPLY CENTER COLUMBUS COLUMBUS, OHIO 43218-3990	SIZE A	REVISION LEVEL D	5962-96673 SHEET 20
---	------------------	---------------------	--------------------------------------

STANDARD MICROCIRCUIT DRAWING BULLETIN

DATE: 09-06-15

Approved sources of supply for SMD 5962-96673 are listed below for immediate acquisition information only and shall be added to MIL-HDBK-103 and QML-38535 during the next revision. MIL-HDBK-103 and QML-38535 will be revised to include the addition or deletion of sources. The vendors listed below have agreed to this drawing and a certificate of compliance has been submitted to and accepted by DSCC-VA. This information bulletin is superseded by the next dated revision of MIL-HDBK-103 and QML-38535. DSCC maintains an online database of all current sources of supply at <http://www.dscclia.mil/Programs/Smcr/>.

Standard microcircuit drawing PIN <u>1/</u>	Vendor CAGE number	Vendor similar PIN <u>2/</u>
5962R9667301VEC	34371	CD4555BDMSR
5962R9667301VXC	34371	CD4555BKMSR
5962R9667301V9A	<u>3/</u>	CD4555BHRSR
5962R9667302VEC	<u>3/</u>	CD4556BDMSR
5962R9667302VXC	<u>3/</u>	CD4556BKMSR
5962R9667302V9A	<u>3/</u>	CD4556BHRSR
5962R9667303VEC	<u>3/</u>	CD4555BDNSR
5962R9667303VXC	<u>3/</u>	CD4555BKNSR
5962R9667303V9A	<u>3/</u>	CD4555BHNSR
5962R9667304VEC	<u>3/</u>	CD4556BNSR
5962R9667304VXC	<u>3/</u>	CD4556BKNSR
5962R9667304V9A	<u>3/</u>	CD4556BHNSR

1/ The lead finish shown for each PIN representing a hermetic package is the most readily available from the manufacturer listed for that part. If the desired lead finish is not listed contact the vendor to determine its availability.

2/ Caution. Do not use this number for item acquisition. Items acquired to this number may not satisfy the performance requirements of this drawing.

3/ Not available from an approved source of supply

Vendor CAGE
number
34371

Vendor name
and address
Intersil Corporation
1001 Murphy Ranch Road
Milpitas, CA 95035-6803

The information contained herein is disseminated for convenience only and the Government assumes no liability whatsoever for any inaccuracies in the information bulletin.