

| REVISIONS | | | |
|-----------|---|-----------------|-----------|
| LTR | DESCRIPTION | DATE (YR-MO-DA) | APPROVED |
| A | Make change to table IIB. - ro | 00-02-15 | R. MONNIN |
| B | Add case outlines E and 2. Make changes to V_{REF} , I_{SC} , dF_{O}/D_V , V_{CLKH} , I_{OS} , $CMRR$, V_{TH} , and V_{SATL1} tests as specified in table I. - ro | 01-02-15 | R. MONNIN |
| C | Make change to the ambient operating temperature range. - ro | 01-03-12 | R. MONNIN |
| D | Add new footnote to the soft start section as specified in table I and figure 1. - ro | 01-04-25 | R. MONNIN |
| E | Make changes to V_{REF} , V_{OM} , I_{OS} , and I_{DCHG} tests as specified in table I. Make change to I_{B} delta limit as specified in table IIB. - ro. | 02-10-10 | R. MONNIN |
| F | Add footnotes under 1.3, 1.4, and 1.5. Add two footnotes under Table I. Make changes to the conditions column for V_{LINE} , V_{OM} , dF_{O}/D_V , F_{OM} , $PSRR$, and I_{SU} tests as specified under Table I. Make corrections to figure 2 and figure 3. - ro | 06-04-07 | R. MONNIN |
| G | Make corrections to the logic diagram under figure 2. - ro | 08-12-09 | R. HEBER |



| | | | | | | | | | | | | | | | | | | | | |
|--|-----------------------------------|----|----|----|----|----|--|---------------------------|-------------------|---|---|---|----|----|----|----|----|---|---|---|
| REV | | | | | | | | | | | | | | | | | | | | |
| SHEET | | | | | | | | | | | | | | | | | | | | |
| REV | G | G | G | G | G | G | | | | | | | | | | | | | | |
| SHEET | 15 | 16 | 17 | 18 | 19 | 20 | | | | | | | | | | | | | | |
| REV STATUS OF SHEETS | REV | | | G | G | G | G | G | G | G | G | G | G | G | G | G | G | G | G | G |
| | SHEET | | | 1 | 2 | 3 | 4 | 5 | 6 | 7 | 8 | 9 | 10 | 11 | 12 | 13 | 14 | | | |
| PMIC N/A | PREPARED BY RICK OFFICER | | | | | | DEFENSE SUPPLY CENTER COLUMBUS COLUMBUS, OHIO 43218-3990 http://www.dsc.dla.mil | | | | | | | | | | | | | |
| STANDARD MICROCIRCUIT DRAWING THIS DRAWING IS AVAILABLE FOR USE BY ALL DEPARTMENTS AND AGENCIES OF THE DEPARTMENT OF DEFENSE AMSC N/A | CHECKED BY RAJESH PITHADIA | | | | | | | | | | | | | | | | | | | |
| | APPROVED BY RAYMOND MONNIN | | | | | | | | | | | | | | | | | | | |
| | DRAWING APPROVAL DATE 00-01-24 | | | | | | | | | | | | | | | | | | | |
| | REVISION LEVEL G | | | | | | SIZE A | CAGE CODE 67268 | 5962-99558 | | | | | | | | | | | |
| SHEET 1 OF 20 | | | | | | | | | | | | | | | | | | | | |

1. SCOPE

1.1 Scope. This drawing documents three product assurance class levels consisting of high reliability (device classes Q and M), space application (device class V) and for appropriate satellite and similar applications (device class T). A choice of case outlines and lead finishes are available and are reflected in the Part or Identifying Number (PIN). When available, a choice of Radiation Hardness Assurance (RHA) levels is reflected in the PIN. For device class T, the user is encouraged to review the manufacturer's Quality Management (QM) plan as part of their evaluation of these parts and their acceptability in the intended application.

1.2 PIN. The PIN is as shown in the following example:

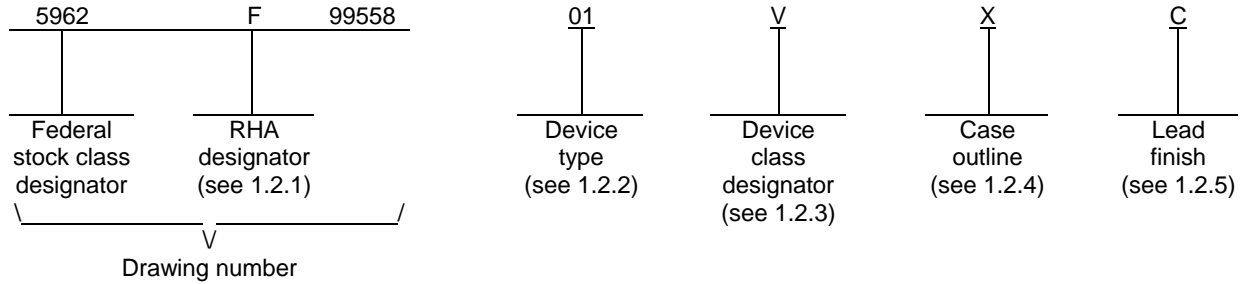

1.2.1 RHA designator. Device classes Q, T and V RHA marked devices meet the MIL-PRF-38535 specified RHA levels and are marked with the appropriate RHA designator. Device class M RHA marked devices meet the MIL-PRF-38535, appendix A specified RHA levels and are marked with the appropriate RHA designator. A dash (-) indicates a non-RHA device.

1.2.2 Device type(s). The device type(s) identify the circuit function as follows:

| <u>Device type</u> | <u>Generic number</u> | <u>Circuit function</u> |
|--------------------|-----------------------|---|
| 01 | HS-1825ARH | Radiation hardened DI dual output pulse width modulator |

1.2.3 Device class designator. The device class designator is a single letter identifying the product assurance level as follows:

| <u>Device class</u> | <u>Device requirements documentation</u> |
|---------------------|---|
| M | Vendor self-certification to the requirements for MIL-STD-883 compliant, non-JAN class level B microcircuits in accordance with MIL-PRF-38535, appendix A |
| Q, V | Certification and qualification to MIL-PRF-38535 |
| T | Certification and qualification to MIL-PRF-38535 with performance as specified in the device manufacturers approved quality management plan. |

1.2.4 Case outline(s). The case outline(s) are as designated in MIL-STD-1835 and as follows:

| <u>Outline letter</u> | <u>Descriptive designator</u> | <u>Terminals</u> | <u>Package style</u> |
|-----------------------|-------------------------------|------------------|------------------------------|
| E | CDIP2-T16 | 16 | Dual-in-line |
| X | CDFP4-F16 | 16 | Flat pack |
| 2 | CQCC1-N20 | 20 | Square leadless chip carrier |

1.2.5 Lead finish. The lead finish is as specified in MIL-PRF-38535 for device classes Q, T and V or MIL-PRF-38535, appendix A for device class M.

| | | | |
|---|------------------|----------------------------|-------------------|
| STANDARD MICROCIRCUIT DRAWING DEFENSE SUPPLY CENTER COLUMBUS COLUMBUS, OHIO 43218-3990 | SIZE A | | 5962-99558 |
| | | REVISION LEVEL G | SHEET 2 |

1.3 Absolute maximum ratings. 1/ 2/ 3/

| | |
|--|-----------------|
| Supply voltage (V_{CC} and V_C 4/) | 36 V dc |
| Power dissipation (P_D) | 1.6 W |
| Junction temperature (T_J) | +175°C maximum |
| Lead temperature (soldering, 10 seconds) | +260°C maximum |
| Storage temperature range | -65°C to +150°C |
| Thermal resistance, junction-to-case (θ_{JC}): | |
| Cases E and 2 | 18°C/W |
| Case X | 8°C/W |
| Thermal resistance, junction-to-ambient (θ_{JA}): | |
| Cases E and 2 | 70°C/W |
| Case X | 90°C/W |

1.4 Recommended operating conditions. 2/ 3/

| | |
|---|-----------------|
| Supply voltage (V_{CC} and V_C 4/) | 12 V to 30 V |
| Ambient operating temperature range (T_A) | -50°C to +125°C |

1.5 Radiation features:

| | |
|--|------------------------------|
| Maximum total dose available (dose rate = 50 – 300 rad(Si)/s): | |
| Device classes M, Q, or V | 3×10^5 Rads (Si) 5/ |
| Device class T | 1×10^5 Rads (Si) 5/ |
| Latch-up | None 6/ |

- 1/ Stresses above the absolute maximum rating may cause permanent damage to the device. Extended operation at the maximum levels may degrade performance and affect reliability.
- 2/ Unless otherwise noted, all voltages are referenced to GND.
- 3/ The limits for the parameters specified herein shall apply over the full specified V_{CC} range and ambient temperature range of -50°C to +125°C unless otherwise noted.
- 4/ V_{CC} and V_C must be at the same potential.
- 5/ These parts may be dose rate sensitive in a space environment and may demonstrate enhanced low dose rate effects. Radiation end point limits for the noted parameters are guaranteed only for the conditions specified in MIL-STD-883, method 1019, condition A.
- 6/ Guaranteed by process or design.

| | | | |
|---|------------------|----------------------------|-------------------|
| STANDARD MICROCIRCUIT DRAWING DEFENSE SUPPLY CENTER COLUMBUS COLUMBUS, OHIO 43218-3990 | SIZE A | | 5962-99558 |
| | | REVISION LEVEL G | SHEET 3 |

2. APPLICABLE DOCUMENTS

2.1 Government specification, standards, and handbooks. The following specification, standards, and handbooks form a part of this drawing to the extent specified herein. Unless otherwise specified, the issues of these documents are those cited in the solicitation or contract.

DEPARTMENT OF DEFENSE SPECIFICATION

MIL-PRF-38535 - Integrated Circuits, Manufacturing, General Specification for.

DEPARTMENT OF DEFENSE STANDARDS

MIL-STD-883 - Test Method Standard Microcircuits.
 MIL-STD-1835 - Interface Standard Electronic Component Case Outlines.

DEPARTMENT OF DEFENSE HANDBOOKS

MIL-HDBK-103 - List of Standard Microcircuit Drawings.
 MIL-HDBK-780 - Standard Microcircuit Drawings.

(Copies of these documents are available online at <http://assist.daps.dla.mil/quicksearch/> or from the Standardization Document Order Desk, 700 Robbins Avenue, Building 4D, Philadelphia, PA 19111-5094.)

2.2 Order of precedence. In the event of a conflict between the text of this drawing and the references cited herein, the text of this drawing takes precedence. Nothing in this document, however, supersedes applicable laws and regulations unless a specific exemption has been obtained.

3. REQUIREMENTS

3.1 Item requirements. The individual item requirements for device classes Q, T and V shall be in accordance with MIL-PRF-38535 and as specified herein or as modified in the device manufacturer's Quality Management (QM) plan. The modification in the QM plan shall not affect the form, fit, or function as described herein. The individual item requirements for device class M shall be in accordance with MIL-PRF-38535, appendix A for non-JAN class level B devices and as specified herein.

3.1.1 Microcircuit die. For the requirements of microcircuit die, see appendix A to this document.

3.2 Design, construction, and physical dimensions. The design, construction, and physical dimensions shall be as specified in MIL-PRF-38535 and herein for device classes Q, T and V or MIL-PRF-38535, appendix A and herein for device class M.

3.2.1 Case outlines. The case outlines shall be in accordance with 1.2.4 herein.

3.2.2 Terminal connections. The terminal connections shall be as specified on figure 1.

3.2.3 Logic diagram. The logic diagram shall be as specified on figure 2.

3.2.4 Irradiation test connections. The irradiation test connections shall be as specified in figure 3.

3.3 Electrical performance characteristics and postirradiation parameter limits. Unless otherwise specified herein, the electrical performance characteristics and postirradiation parameter limits are as specified in table I and shall apply over the full ambient operating temperature range.

3.4 Electrical test requirements. The electrical test requirements shall be the subgroups specified in table IIA. The electrical tests for each subgroup are defined in table I.

| | | | |
|--|------------------|----------------------------|-------------------|
| STANDARD MICROCIRCUIT DRAWING DEFENSE SUPPLY CENTER COLUMBUS COLUMBUS, OHIO 43218-3990 | SIZE A | | 5962-99558 |
| | | REVISION LEVEL G | SHEET 4 |

TABLE I. Electrical performance characteristics.

| Test | Symbol | Test conditions <u>1/ 2/</u> -50°C ≤ T _A ≤ +125°C unless otherwise specified | Device type | Group A subgroups | Limits | | Unit |
|------------------------|---------------------------------|---|-------------|-------------------|--------|------|------|
| | | | | | Min | Max | |
| Reference section | | | | | | | |
| Output voltage | V _{REF} | | 01 | 1 | 5.05 | 5.15 | V |
| | | | | 2,3 | 5.00 | 5.20 | |
| | | | | M, D, P, L, R, F | 1 | 5.00 | |
| Line regulation | V _{LINE} | 12 < V _S < 20 V <u>3/</u> | 01 | 1 | -15 | 15 | mV |
| | | | | 2,3 | -20 | 20 | |
| | | | | M,D,P,L,R,F | 1 | -20 | |
| Load regulation | V _{LOAD} | 1 mA < I _{OUT} < 10 mA | 01 | 1 | -25 | 25 | mV |
| | | | | 2,3 | -50 | 50 | |
| | | | | M,D,P,L,R,F | 1 | -50 | |
| Total output variation | V _{OM} | V _S = 12 V, 20 V, <u>3/</u> I _L = 1 mA, 10 mA | 01 | 1 | 5.00 | 5.20 | V |
| | | | | 2,3 | 4.95 | 5.25 | |
| | | | | M,D,P,L,R,F | 1 | 4.95 | |
| Short circuit current | I _{SC} | V _{REF} = 0 V | 01 | 1 | 30 | | mA |
| | | | | 2,3 | 20 | | |
| | | | | M,D,P,L,R,F | 1 | 20 | |
| Oscillator section | | | | | | | |
| Initial accuracy | F _O | | 01 | 4 | 350 | 425 | kHz |
| | | | | 5,6 | 300 | 425 | |
| | | | | M,D,P,L,R,F | 4 | 300 | |
| Voltage stability | dF _O /D _V | 12 V < V _S < 20 V <u>3/</u> | 01 | 4 | -2 | 2 | % |
| | | | | 5,6 | -7 | 7 | |
| | | | | M,D,P,L,R,F | 4 | -3 | |
| Total variation | F _{OM} | V _S = 12 V, 20 V <u>3/</u> | 01 | 4 | 350 | 425 | kHz |
| | | | | 5,6 | 300 | 425 | |
| | | | | M,D,P,L,R,F | 4 | 300 | |
| Clock out high voltage | V _{CLKH} | | 01 | 1 | 4.0 | | V |
| | | | | 2,3 | 3.75 | | |
| | | | | M,D,P,L,R,F | 1 | 3.75 | |
| Clock out low voltage | V _{CLKL} | | 01 | 1,2,3 | | 0.2 | V |
| | | | | M,D,P,L,R,F | 1 | | |

See footnotes at end of table.

| | | | |
|---|------------------|----------------------------|-------------------|
| STANDARD MICROCIRCUIT DRAWING DEFENSE SUPPLY CENTER COLUMBUS COLUMBUS, OHIO 43218-3990 | SIZE A | | 5962-99558 |
| | | REVISION LEVEL G | SHEET 5 |

TABLE I. Electrical performance characteristics. – Continued.

| Test | Symbol | Test conditions $\frac{1}{2}$ / $-50^{\circ}\text{C} \leq T_A \leq +125^{\circ}\text{C}$ unless otherwise specified | Device type | Group A subgroups | Limits | | Unit |
|--|-------------------|---|----------------|----------------------|--------|-----|------|
| | | | | | Min | Max | |
| Error amplification section | | | | | | | |
| Input offset voltage | V _{OS} | V _{CM} = 3.0 V, V _O = 3.0 V M,D,P,L,R,F | 01 | 1,2,3 | -10 | 10 | mV |
| | | | | 1 | -10 | 10 | |
| Input bias current | I _{IB} | V _{CM} = 3.0 V, V _O = 3.0 V M,D,P,L,R,F | 01 | 1,2,3 | -1 | 1 | μA |
| | | | | 1 | -1 | 1 | |
| Input offset current | I _{OS} | V _{CM} = 3.0 V, V _O = 3.0 V M,D,P,L,R,F | 01 | 1,2,3 | -4 | 4 | μA |
| | | | | 1 | -4 | 4 | |
| Open loop gain | A _{VOL} | 1 V < V _O < 4 V M,D,P,L,R,F | 01 | 4,5,6 | 60 | | dB |
| | | | | 4 | 60 | | |
| Common mode rejection ratio | CMRR | 1.5 V < V _{CM} < 4.0 V M,D,P,L,R,F | 01 | 4 | 65 | | dB |
| | | | | 5,6 | 45 | | |
| | | | | 4 | 65 | | |
| Power supply rejection ratio | PSRR | 12 V < V _S < 20 V $\frac{3}{}$ M,D,P,L,R,F | 01 | 4,5,6 | 80 | | dB |
| | | | | 4 | 80 | | |
| Output sink current | I _{OSK} | V _{E/A OUT} = 1.0 V M,D,P,L,R,F | 01 | 1,2,3 | 1 | | mA |
| | | | | 1 | 1 | | |
| Output source current | I _{OSC} | V _{E/A OUT} = 4.0 V M,D,P,L,R,F | 01 | 1,2,3 | -0.5 | | mA |
| | | | | 1 | -0.5 | | |
| Output high voltage | V _{OH1} | I _{E/A OUT} = -0.5 mA M,D,P,L,R,F | 01 | 1,2,3 | 4.0 | | V |
| | | | | 1 | 4.0 | | |
| Output low voltage | V _{OL1} | I _{E/A OUT} = 1 mA M,D,P,L,R,F | 01 | 1,2,3 | | 1.0 | V |
| | | | | 1 | | 1.0 | |
| Pulse width modulator (PWM) comparator section | | | | | | | |
| Ramp bias current | I _{RAMP} | V _{RAMP} = 0 V M,D,P,L,R,F | 01 | 1,2,3 | | -8 | μA |
| | | | | 1 | | -8 | |
| Duty cycle range | DCRNG | M,D,P,L,R,F | 01 | 4,5,6 | 40 | | % |
| | | | | 4 | 40 | | |
| E/A out zero DC threshold voltage | V _{TH} | Ramp voltage = 0 V M,D,P,L,R,F | 01 | 1,2,3 | 0.89 | | V |
| | | | | 1 | 0.89 | | |

See footnotes at end of table.

| | | | |
|---|------------------|----------------------------|-------------------|
| STANDARD MICROCIRCUIT DRAWING DEFENSE SUPPLY CENTER COLUMBUS COLUMBUS, OHIO 43218-3990 | SIZE A | | 5962-99558 |
| | | REVISION LEVEL G | SHEET 6 |

TABLE I. Electrical performance characteristics – Continued.

| Test | Symbol | Test conditions <u>1/ 2/</u> -50°C ≤ T _A ≤ +125°C unless otherwise specified | Device type | Group A subgroups | Limits | | Unit |
|--|--------------------|---|-------------|-------------------|--------|------|------|
| | | | | | Min | Max | |
| Soft start section <u>4/</u> | | | | | | | |
| Charge current | I _{CHG} | Soft start voltage = 2.5 V M,D,P,L,R,F | 01 | 1 | 8 | 20 | μA |
| | | | | 2,3 | 8 | 25 | |
| | | | | 1 | 8 | 25 | |
| Discharge current | I _{DCHG} | Soft start voltage = 2.5 V M,D,P,L,R,F | 01 | 1,2,3 | 0.1 | 0.5 | mA |
| | | | | 1 | 0.1 | 0.5 | |
| | | | | | | | |
| Current limit / Start sequence / Fault section | | | | | | | |
| Restart threshold | V _{RS} | M,D,P,L,R,F | 01 | 1,2,3 | | 0.5 | V |
| | | | | 1 | | 0.5 | |
| ILIM bias current | I _{BLIM} | 0 < V _{ILIM} < 2 V M,D,P,L,R,F | 01 | 1,2,3 | | 15 | μA |
| | | | | 1 | | 15 | |
| Current limit threshold | V _{LIMIT} | M,D,P,L,R,F | 01 | 1 | 0.95 | 1.10 | V |
| | | | | 2,3 | 0.90 | 1.10 | |
| | | | | 1 | 0.90 | 1.10 | |
| Over current threshold | V _{OVER} | M,D,P,L,R,F | 01 | 1,2,3 | 1.14 | 1.26 | V |
| | | | | 1 | 1.14 | 1.26 | |
| Output section | | | | | | | |
| Output low saturation 1 | V _{SATL1} | I _{OUT} = 20 mA M,D,P,L,R,F | 01 | 1 | | 0.8 | V |
| | | | | 2,3 | | 1.0 | |
| | | | | 1 | | 0.8 | |
| Output low saturation 2 | V _{SATL2} | I _{OUT} = 200 mA M,D,P,L,R,F | 01 | 1,2,3 | | 2.2 | V |
| | | | | 1 | | 2.2 | |
| Output high saturation 1 | V _{SATH1} | I _{OUT} = 20 mA M,D,P,L,R,F | 01 | 1,2,3 | 10 | | V |
| | | | | 1 | 10 | | |
| Output high saturation 2 | V _{SATH2} | I _{OUT} = 200 mA M,D,P,L,R,F | 01 | 1,2,3 | 9 | | V |
| | | | | 1 | 9 | | |
| Under voltage lockout (UVLO) output low saturation voltage | V _{OLS} | I _O = 20 mA M,D,P,L,R,F | 01 | 1,2,3 | | 1.2 | V |
| | | | | 1 | | 1.2 | |

See footnotes at end of table.

| | | | |
|---|------------------|----------------------------|-------------------|
| STANDARD MICROCIRCUIT DRAWING DEFENSE SUPPLY CENTER COLUMBUS COLUMBUS, OHIO 43218-3990 | SIZE A | | 5962-99558 |
| | | REVISION LEVEL G | SHEET 7 |

TABLE I. Electrical performance characteristics – Continued.

| Test | Symbol | Test conditions ^{1/ 2/} -50°C ≤ T _A ≤ +125°C unless otherwise specified | Device type | Group A subgroups | Limits | | Unit |
|---|--------------------|---|-------------|-------------------|--------|-----|------|
| | | | | | Min | Max | |
| Under voltage section | | | | | | | |
| Start threshold voltage | V _{START} | | 01 | 1,2,3 | 8.4 | 9.6 | V |
| | | | | M,D,P,L,R,F | 1 | 8.4 | |
| Stop threshold voltage | V _{STOP} | | 01 | 1,2,3 | | 9.6 | V |
| | | | | M,D,P,L,R,F | 1 | | |
| Under voltage lockout (UVLO) hysteresis | V _{HYS} | | 01 | 1,2,3 | 0.3 | 1.2 | V |
| | | | | M,D,P,L,R,F | 1 | 0.3 | |
| Supply current section | | | | | | | |
| Startup current | I _{SU} | V _S = 8.0 V ^{3/} | 01 | 1,2,3 | | 300 | μA |
| | | | | M,D,P,L,R,F | 1 | | |
| Supply current | I _{CC} | Inverting input, RAMP, and current LIM / SD voltage = 0 V, non-inverting input voltage = 1.0 V | 01 | 1,2,3 | | 36 | mA |
| | | | | M,D,P,L,R,F | 1 | | |

^{1/} Devices supplied to this drawing meet all levels M, D, P, L, R, and F for device classes M, Q, and V and for device class T, will meet levels M, D, P, L, and R of irradiation. However, this device is only tested at the "F" level for device classes M, Q, and V and at the "R" level for device class T (see 1.5 herein). Pre and post irradiation values are identical unless otherwise specified in table I. When performing post irradiation electrical measurements for any RHA level, T_A = +25°C.

^{2/} These parts may be dose rate sensitive in a space environment and may demonstrate enhanced low dose rate effects. Radiation end point limits for the noted parameters are guaranteed only for the conditions specified in MIL-STD-883, method 1019, condition A.

^{3/} V_S = V_C = V_{CC}. Both V_{CC} and V_C must be at the same potential.

^{4/} Grounding of the SOFT START pin does not inhibit the outputs.

| | | | |
|---|------------------|----------------------------|-------------------|
| STANDARD MICROCIRCUIT DRAWING DEFENSE SUPPLY CENTER COLUMBUS COLUMBUS, OHIO 43218-3990 | SIZE A | | 5962-99558 |
| | | REVISION LEVEL G | SHEET 8 |

| | | |
|-----------------|----------------------------|----------------------------|
| Device type | 01 | |
| Case outlines | E and X | 2 |
| Terminal number | Terminal symbol | |
| 1 | INV | NC |
| 2 | NON-INV | INV |
| 3 | E/A OUT | NON-INV |
| 4 | CLOCK | E/A OUT |
| 5 | R _T | CLOCK/LEB |
| 6 | C _T | NC |
| 7 | RAMP | R _T |
| 8 | SOFT START (SEE NOTE 2) | C _T |
| 9 | ILIM/SD | RAMP |
| 10 | GND | SOFT START (SEE NOTE 2) |
| 11 | OUTPUT A | NC |
| 12 | POWER GND | ILIM/SD |
| 13 | V _C | GND |
| 14 | OUTPUT B | OUTPUT A |
| 15 | V _{CC} | POWER GND |
| 16 | V _{REF} 5.1 V | NC |
| 17 | --- | V _C |
| 18 | --- | OUTPUT B |
| 19 | --- | V _{CC} |
| 20 | --- | V _{REF} 5.1 V |

NOTES:

1. NC = No connection
2. Grounding of the SOFT START pin does not inhibit the outputs.

FIGURE 1. Terminal connections.

| | | | |
|---|------------------|----------------------------|-------------------|
| STANDARD MICROCIRCUIT DRAWING DEFENSE SUPPLY CENTER COLUMBUS COLUMBUS, OHIO 43218-3990 | SIZE A | | 5962-99558 |
| | | REVISION LEVEL G | SHEET 9 |

A=LOW IF LEADING EDGE BLANKING (LEB) IS OVER AND PWM CALLS FOR OFF
 B=LOW IF CURRENT LIMIT (CL) IS HIGH AND LEB IS OVER

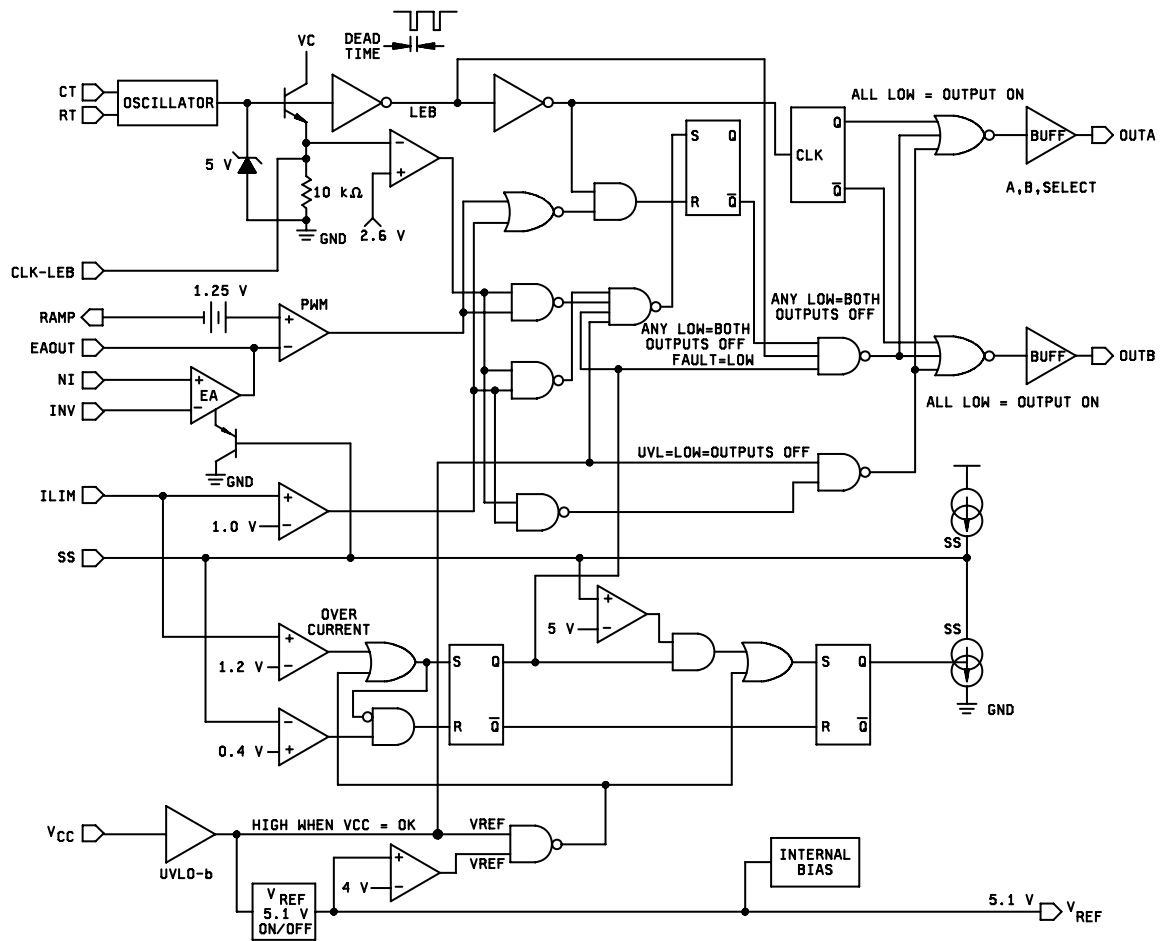

FIGURE 2. Logic diagram.

**STANDARD
 MICROCIRCUIT DRAWING**
 DEFENSE SUPPLY CENTER COLUMBUS
 COLUMBUS, OHIO 43218-3990

SIZE
A

5962-99558

REVISION LEVEL
G

SHEET
 10

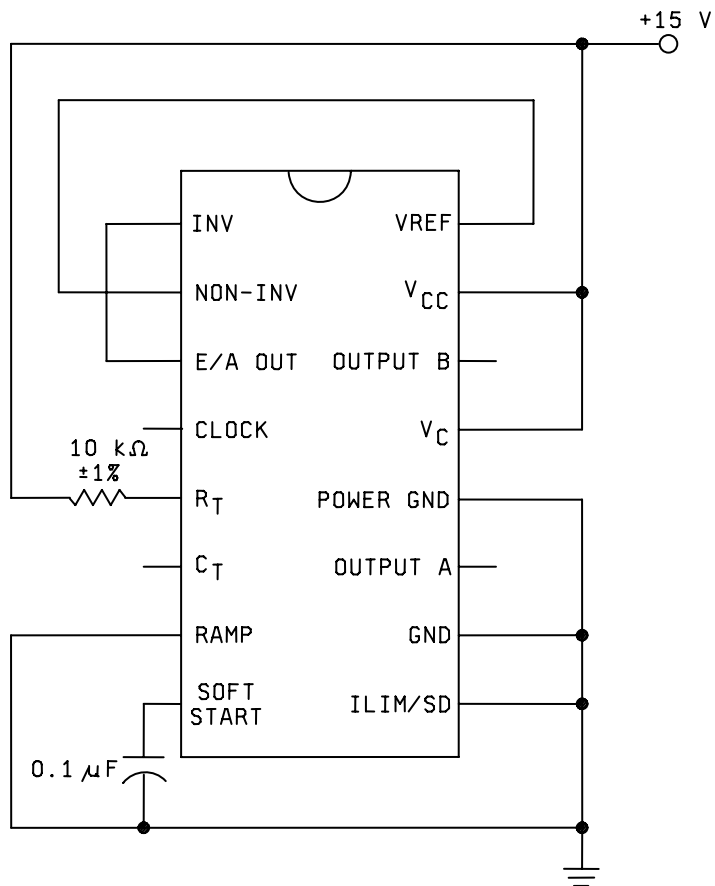

FIGURE 3. Irradiation connections.

| | | | |
|---|------------------|----------------------------|-------------------|
| STANDARD MICROCIRCUIT DRAWING DEFENSE SUPPLY CENTER COLUMBUS COLUMBUS, OHIO 43218-3990 | SIZE A | | 5962-99558 |
| | | REVISION LEVEL G | SHEET 11 |

3.5 Marking. The part shall be marked with the PIN listed in 1.2 herein. In addition, the manufacturer's PIN may also be marked. For packages where marking of the entire SMD PIN is not feasible due to space limitations, the manufacturer has the option of not marking the "5962-" on the device. For RHA product using this option, the RHA designator shall still be marked. Marking for device classes Q, T and V shall be in accordance with MIL-PRF-38535. Marking for device class M shall be in accordance with MIL-PRF-38535, appendix A.

3.5.1 Certification/compliance mark. The certification mark for device classes Q, T and V shall be a "QML" or "Q" as required in MIL-PRF-38535. The compliance mark for device class M shall be a "C" as required in MIL-PRF-38535, appendix A.

3.6 Certificate of compliance. For device classes Q, T and V, a certificate of compliance shall be required from a QML-38535 listed manufacturer in order to supply to the requirements of this drawing (see 6.6.1 herein). For device class M, a certificate of compliance shall be required from a manufacturer in order to be listed as an approved source of supply in MIL-HDBK-103 (see 6.6.2 herein). The certificate of compliance submitted to DSCC-VA prior to listing as an approved source of supply for this drawing shall affirm that the manufacturer's product meets, for device classes Q, T and V, the requirements of MIL-PRF-38535 and herein or for device class M, the requirements of MIL-PRF-38535, appendix A and herein.

3.7 Certificate of conformance. A certificate of conformance as required for device classes Q, T and V in MIL-PRF-38535 or for device class M in MIL-PRF-38535, appendix A shall be provided with each lot of microcircuits delivered to this drawing.

3.8 Notification of change for device class M. For device class M, notification to DSCC-VA of change of product (see 6.2 herein) involving devices acquired to this drawing is required for any change that affects this drawing.

3.9 Verification and review for device class M. For device class M, DSCC, DSCC's agent, and the acquiring activity retain the option to review the manufacturer's facility and applicable required documentation. Offshore documentation shall be made available onshore at the option of the reviewer.

3.10 Microcircuit group assignment for device class M. Device class M devices covered by this drawing shall be in microcircuit group number 90 (see MIL-PRF-38535, appendix A).

4. VERIFICATION

4.1 Sampling and inspection. For device classes Q, and V, sampling and inspection procedures shall be in accordance with MIL-PRF-38535 or as modified in the device manufacturer's Quality Management (QM) plan, including screening (4.2), qualification (4.3), and conformance inspection (4.4). The modification in the QM plan shall not affect the form, fit, or function as described herein. For device class T, sampling and inspection procedures shall be in accordance with MIL-PRF-38535 and the device manufacturer's QM plan including screening, qualification, and conformance inspection. The performance envelope and reliability information shall be as specified in the manufacturer's QM plan. For device class M, sampling and inspection procedures shall be in accordance with MIL-PRF-38535, appendix A.

4.2 Screening. For device classes Q and V, screening shall be in accordance with MIL-PRF-38535, and shall be conducted on all devices prior to qualification and technology conformance inspection. For device class M, screening shall be in accordance with method 5004 of MIL-STD-883, and shall be conducted on all devices prior to quality conformance inspection. For device class T, screening shall be in accordance with the device manufacturer's Quality Management (QM) plan, and shall be conducted on all devices prior to qualification and technology conformance inspection.

4.2.1 Additional criteria for device class M.

a. Burn-in test, method 1015 of MIL-STD-883.

(1) Test condition A, B, C, or D. The test circuit shall be maintained by the manufacturer under document revision level control and shall be made available to the preparing or acquiring activity upon request. The test circuit shall specify the inputs, outputs, biases, and power dissipation, as applicable, in accordance with the intent specified in method 1015.

(2) $T_A = +125^{\circ}\text{C}$, minimum.

b. Interim and final electrical test parameters shall be as specified in table IIA herein.

| | | | |
|---|------------------|----------------------------|-------------------|
| STANDARD MICROCIRCUIT DRAWING DEFENSE SUPPLY CENTER COLUMBUS COLUMBUS, OHIO 43218-3990 | SIZE A | | 5962-99558 |
| | | REVISION LEVEL G | SHEET 12 |

TABLE IIA. Electrical test requirements.

| Test requirements | Subgroups (in accordance with MIL-STD-883, method 5005, table I) | Subgroups (in accordance with MIL-PRF-38535, table III) | | |
|---|---|---|------------------------------|-------------------------|
| | Device class M | Device class Q | Device class V | Device class T |
| Interim electrical parameters (see 4.2) | 1,4 | 1,4 | 1,4 | As specified in QM plan |
| Final electrical parameters (see 4.2) | 1,2,3,4,5,6 <u>1/</u> | 1,2,3,4,5,6 <u>1/</u> | 1,2,3,4, <u>2/ 3/</u> 5,6 | As specified in QM plan |
| Group A test requirements (see 4.4) | 1,2,3,4,5,6 | 1,2,3,4,5,6 | 1,2,3,4,5,6 | As specified in QM plan |
| Group C end-point electrical parameters (see 4.4) | 1,2,3,4,5,6 | 1,2,3,4,5,6 | 1,2,3,4,5,6 <u>3/</u> | As specified in QM plan |
| Group D end-point electrical parameters (see 4.4) | 1,4 | 1,4 | 1,4 | As specified in QM plan |
| Group E end-point electrical parameters (see 4.4) | 1,4 | 1,4 | 1,4 | As specified in QM plan |

1/ PDA applies to subgroups 1 and 4.

2/ PDA applies to subgroups 1, 4, and Δ's.

3/ Delta limits as specified in table IIB herein shall be required where specified, and the delta values shall be completed with reference to the zero hour electrical parameters (see table I).

TABLE IIB. Burn-in delta parameters (+25°) and group C delta parameters.

| Parameters <u>1/</u> | Symbol | Delta limits |
|----------------------|-----------------|--------------|
| Supply current | I _{CC} | ±2.0 mA |
| Input bias current | I _{IB} | ±200 nA |

1/ These parameters shall be recorded before and after the required burn-in and life test to determine delta limits.

4.2.2 Additional criteria for device classes Q, T and V.

- a. The burn-in test duration, test condition and test temperature, or approved alternatives shall be as specified in the device manufacturer's QM plan in accordance with MIL-PRF-38535. The burn-in test circuit shall be maintained under document revision level control of the device manufacturer's Technology Review Board (TRB) in accordance with MIL-PRF-38535 and shall be made available to the acquiring or preparing activity upon request. The test circuit shall specify the inputs, outputs, biases, and power dissipation, as applicable, in accordance with the intent specified in method 1015 of MIL-STD-883.
- b. For device classes Q, T and V interim and final electrical test parameters shall be as specified in table IIA herein.
- c. Additional screening for device class V beyond the requirements of device class Q shall be as specified in MIL-PRF-38535, appendix B.

| | | | |
|---|------------------|----------------------------|-------------------|
| STANDARD MICROCIRCUIT DRAWING DEFENSE SUPPLY CENTER COLUMBUS COLUMBUS, OHIO 43218-3990 | SIZE A | | 5962-99558 |
| | | REVISION LEVEL G | SHEET 13 |

4.3 Qualification inspection for device classes Q, T and V. Qualification inspection for device classes Q and V shall be in accordance with MIL-PRF-38535. Qualification inspection for device class T shall be in accordance with the device manufacturer's Quality Management (QM) plan. Inspections to be performed shall be those specified in MIL-PRF-38535 and herein for groups A, B, C, D, and E inspections (see 4.4.1 through 4.4.4).

4.4 Conformance inspection. Technology conformance inspection for classes Q and V shall be in accordance with MIL-PRF-38535 including groups A, B, C, D, and E inspections and as specified herein. Quality conformance inspection for device class M shall be in accordance with MIL-PRF-38535, appendix A and as specified herein. Inspections to be performed for device class M shall be those specified in method 5005 of MIL-STD-883 and herein for groups A, B, C, D, and E inspections (see 4.4.1 through 4.4.4). Technology conformance inspection for class T shall be in accordance with the device manufacturer's Quality Management (QM) plan.

4.4.1 Group A inspection.

- a. Tests shall be as specified in table IIA herein.
- b. Subgroups 7, 8, 9, 10, and 11 in table I, method 5005 of MIL-STD-883 shall be omitted.

4.4.2 Group C inspection. The group C inspection end-point electrical parameters shall be as specified in table IIA herein.

4.4.2.1 Additional criteria for device class M. Steady-state life test conditions, method 1005 of MIL-STD-883:

- a. Test condition A, B, C, or D. The test circuit shall be maintained by the manufacturer under document revision level control and shall be made available to the preparing or acquiring activity upon request. The test circuit shall specify the inputs, outputs, biases, and power dissipation, as applicable, in accordance with the intent specified in method 1005 of MIL-STD-883.
- b. $T_A = +125^\circ\text{C}$, minimum.
- c. Test duration: 1,000 hours, except as permitted by method 1005 of MIL-STD-883.

4.4.2.2 Additional criteria for device classes Q, T and V. The steady-state life test duration, test condition and test temperature, or approved alternatives shall be as specified in the device manufacturer's QM plan in accordance with MIL-PRF-38535. The test circuit shall be maintained under document revision level control by the device manufacturer's TRB in accordance with MIL-PRF-38535 and shall be made available to the acquiring or preparing activity upon request. The test circuit shall specify the inputs, outputs, biases, and power dissipation, as applicable, in accordance with the intent specified in method 1005 of MIL-STD-883.

4.4.3 Group D inspection. The group D inspection end-point electrical parameters shall be as specified in table IIA herein.

4.4.4 Group E inspection. Group E inspection is required only for parts intended to be marked as radiation hardness assured (see 3.5 herein). RHA levels for device classes M, Q and V shall be as specified in MIL-PRF-38535. End-point electrical parameters shall be as specified in table IIA herein.

4.4.4.1 Group E inspection for device class T. For device class T, the RHA requirements shall be in accordance with the class T radiation requirements of MIL-PRF-38535. End-point electrical parameters shall be as specified in table IIA herein.

4.4.4.2 Total dose irradiation testing. Total dose irradiation testing shall be performed in accordance with MIL-STD-883 method 1019, condition A, and as specified herein. For device class T, the total dose requirements shall be in accordance with the class T radiation requirements of MIL-PRF-38535 (see 1.5 herein).

4.4.4.2.1 Accelerated annealing testing. Accelerated annealing testing shall be performed on all devices requiring a RHA level greater than 5k rads (Si). The post-anneal end-point electrical parameter limits shall be as specified in table I herein and shall be the pre-irradiation end-point electrical parameter limits at $25^\circ\text{C} \pm 5^\circ\text{C}$. Testing shall be performed at initial qualification and after any design or process changes which may affect the RHA response of the device.

4.5 Methods of inspection. Methods of inspection shall be specified as follows:

4.5.1 Voltage and current. Unless otherwise specified, all voltages given are referenced to the microcircuit GND terminal. Currents given are conventional current and positive when flowing into the referenced terminal.

| | | | |
|---|------------------|----------------------------|-------------------|
| STANDARD MICROCIRCUIT DRAWING DEFENSE SUPPLY CENTER COLUMBUS COLUMBUS, OHIO 43218-3990 | SIZE A | | 5962-99558 |
| | | REVISION LEVEL G | SHEET 14 |

5. PACKAGING

5.1 Packaging requirements. The requirements for packaging shall be in accordance with MIL-PRF-38535 for device classes Q, T and V or MIL-PRF-38535, appendix A for device class M.

6. NOTES

6.1 Intended use. Microcircuits conforming to this drawing are intended for use for Government microcircuit applications (original equipment), design applications, and logistics purposes.

6.1.1 Replaceability. Microcircuits covered by this drawing will replace the same generic device covered by a contractor prepared specification or drawing.

6.1.2 Substitutability. Device class Q devices will replace device class M devices.

6.2 Configuration control of SMD's. All proposed changes to existing SMD's will be coordinated with the users of record for the individual documents. This coordination will be accomplished using DD Form 1692, Engineering Change Proposal.

6.3 Record of users. Military and industrial users should inform Defense Supply Center Columbus when a system application requires configuration control and which SMD's are applicable to that system. DSCC will maintain a record of users and this list will be used for coordination and distribution of changes to the drawings. Users of drawings covering microelectronic devices (FSC 5962) should contact DSCC-VA, telephone (614) 692-0544.

6.4 Comments. Comments on this drawing should be directed to DSCC-VA, Columbus, Ohio 43218-3990, or telephone (614) 692-0547.

6.5 Abbreviations, symbols, and definitions. The abbreviations, symbols, and definitions used herein are defined in MIL-PRF-38535 and MIL-HDBK-1331.

6.6 Sources of supply.

6.6.1 Sources of supply for device classes Q, T and V. Sources of supply for device classes Q, T and V are listed in QML-38535. The vendors listed in QML-38535 have submitted a certificate of compliance (see 3.6 herein) to DSCC-VA and have agreed to this drawing.

6.6.2 Approved sources of supply for device class M. Approved sources of supply for class M are listed in MIL-HDBK-103. The vendors listed in MIL-HDBK-103 have agreed to this drawing and a certificate of compliance (see 3.6 herein) has been submitted to and accepted by DSCC-VA.

| | | | |
|---|------------------|----------------------------|-------------------|
| STANDARD MICROCIRCUIT DRAWING DEFENSE SUPPLY CENTER COLUMBUS COLUMBUS, OHIO 43218-3990 | SIZE A | | 5962-99558 |
| | | REVISION LEVEL G | SHEET 15 |

APPENDIX A
APPENDIX A FORMS A PART OF SMD 5962-99558

A.1 SCOPE

A.1.1 Scope. This appendix establishes minimum requirements for microcircuit die to be supplied under the Qualified Manufacturers List (QML) Program. QML microcircuit die meeting the requirements of MIL-PRF-38535 and the manufacturers approved QM plan for use in monolithic microcircuits, multi-chip modules (MCMs), hybrids, electronic modules, or devices using chip and wire designs in accordance with MIL-PRF-38534 are specified herein. Two product assurance classes consisting of military high reliability (device class Q) and space application (device class V) are reflected in the Part or Identification Number (PIN). When available, a choice of Radiation Hardiness Assurance (RHA) levels are reflected in the PIN.

A.1.2 PIN. The PIN is as shown in the following example:

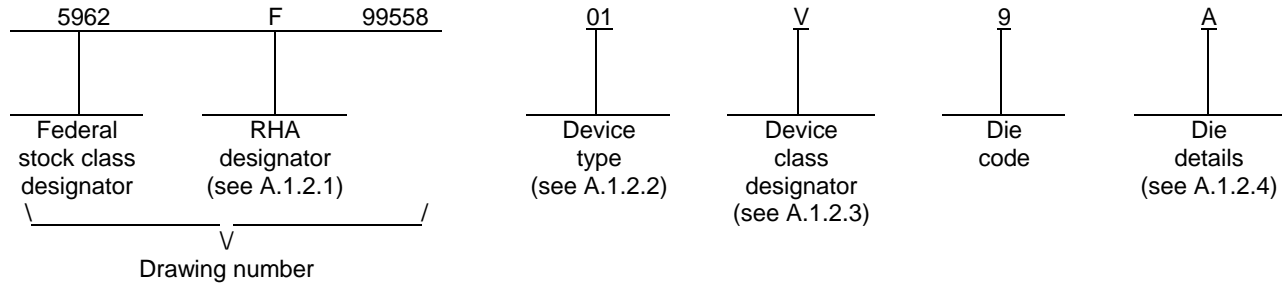

A.1.2.1 RHA designator. Device classes Q and V RHA identified die meet the MIL-PRF-38535 specified RHA levels. A dash (-) indicates a non-RHA die.

A.1.2.2 Device type(s). The device type(s) identify the circuit function as follows:

| <u>Device type</u> | <u>Generic number</u> | <u>Circuit function</u> |
|--------------------|-----------------------|---|
| 01 | HS-1825ARH | Radiation hardened DI dual output pulse width modulator |

A.1.2.3 Device class designator.

| <u>Device class</u> | <u>Device requirements documentation</u> |
|---------------------|--|
| Q or V | Certification and qualification to the die requirements of MIL-PRF-38535 |

| | | | |
|---|------------------|----------------------------|-------------------|
| STANDARD MICROCIRCUIT DRAWING DEFENSE SUPPLY CENTER COLUMBUS COLUMBUS, OHIO 43218-3990 | SIZE A | | 5962-99558 |
| | | REVISION LEVEL G | SHEET 16 |

APPENDIX A
APPENDIX A FORMS A PART OF SMD 5962-99558

A.1.2.4 Die details. The die details designation is a unique letter which designates the die's physical dimensions, bonding pad location(s) and related electrical function(s), interface materials, and other assembly related information, for each product and variant supplied to this appendix.

A.1.2.4.1 Die physical dimensions.

| <u>Die type</u> | <u>Figure number</u> |
|-----------------|----------------------|
| 01 | A-1 |

A.1.2.4.2 Die bonding pad locations and electrical functions.

| <u>Die type</u> | <u>Figure number</u> |
|-----------------|----------------------|
| 01 | A-1 |

A.1.2.4.3 Interface materials.

| <u>Die type</u> | <u>Figure number</u> |
|-----------------|----------------------|
| 01 | A-1 |

A.1.2.4.4 Assembly related information.

| <u>Die type</u> | <u>Figure number</u> |
|-----------------|----------------------|
| 01 | A-1 |

A.1.3 Absolute maximum ratings. See paragraph 1.3 herein for details.

A.1.4 Recommended operating conditions. See paragraph 1.4 herein for details.

| | | | |
|---|------------------|----------------------------|-------------------|
| STANDARD MICROCIRCUIT DRAWING DEFENSE SUPPLY CENTER COLUMBUS COLUMBUS, OHIO 43218-3990 | SIZE A | | 5962-99558 |
| | | REVISION LEVEL G | SHEET 17 |

APPENDIX A
APPENDIX A FORMS A PART OF SMD 5962-99558

A.2 APPLICABLE DOCUMENTS.

A.2.1 Government specification, standards, and handbooks. The following specification, standards, and handbooks form a part of this drawing to the extent specified herein. Unless otherwise specified, the issues of these documents are those cited in the solicitation or contract.

DEPARTMENT OF DEFENSE SPECIFICATION

MIL-PRF-38535 - Integrated Circuits, Manufacturing, General Specification for.

DEPARTMENT OF DEFENSE STANDARD

MIL-STD-883 - Test Method Standard Microcircuits.

DEPARTMENT OF DEFENSE HANDBOOKS

MIL-HDBK-103 - List of Standard Microcircuit Drawings.

MIL-HDBK-780 - Standard Microcircuit Drawings.

(Copies of these documents are available online at <http://assist.daps.dla.mil/quicksearch/> or from the Standardization Document Order Desk, 700 Robbins Avenue, Building 4D, Philadelphia, PA 19111-5094.)

A.2.2 Order of precedence. In the event of a conflict between the text of this drawing and the references cited herein, the text of this drawing takes precedence. Nothing in this document, however, supersedes applicable laws and regulations unless a specific exemption has been obtained.

A.3 REQUIREMENTS

A.3.1 Item requirements. The individual item requirements for device classes Q and V shall be in accordance with MIL-PRF-38535 and as specified herein or as modified in the device manufacturer's Quality Management (QM) plan. The modification in the QM plan shall not affect the form, fit, or function as described herein.

A.3.2 Design, construction and physical dimensions. The design, construction, and physical dimensions shall be as specified in MIL-PRF-38535 and herein and the manufacturer's QM plan for device classes Q and V.

A.3.2.1 Die physical dimensions. The die physical dimensions shall be as specified in A.1.2.4.1 and on figure A-1.

A.3.2.2 Die bonding pad locations and electrical functions. The die bonding pad locations and electrical functions shall be as specified in A.1.2.4.2 and on figure A-1.

A.3.2.3 Interface materials. The interface materials for the die shall be as specified in A.1.2.4.3 and on figure A-1.

A.3.2.4 Assembly related information. The assembly related information shall be as specified in A.1.2.4.4 and on figure A-1.

A.3.2.5 Radiation exposure circuit. The radiation exposure circuit shall be as defined in paragraph 3.2.4 herein.

A.3.3 Electrical performance characteristics and post-irradiation parameter limits. Unless otherwise specified herein, the electrical performance characteristics and post-irradiation parameter limits are as specified in table I of the body of this document.

A.3.4 Electrical test requirements. The wafer probe test requirements shall include functional and parametric testing sufficient to make the packaged die capable of meeting the electrical performance requirements in table I.

A.3.5 Marking. As a minimum, each unique lot of die, loaded in single or multiple stack of carriers, for shipment to a customer, shall be identified with the wafer lot number, the certification mark, the manufacturer's identification and the PIN listed in A.1.2 herein. The certification mark shall be a "QML" or "Q" as required by MIL-PRF-38535.

| | | | |
|---|------------------|----------------------------|-------------------|
| STANDARD MICROCIRCUIT DRAWING DEFENSE SUPPLY CENTER COLUMBUS COLUMBUS, OHIO 43218-3990 | SIZE A | | 5962-99558 |
| | | REVISION LEVEL G | SHEET 18 |

APPENDIX A
APPENDIX A FORMS A PART OF SMD 5962-99558

A.3.6 Certification of compliance. For device classes Q and V, a certificate of compliance shall be required from a QML-38535 listed manufacturer in order to supply to the requirements of this drawing (see A.6.4 herein). The certificate of compliance submitted to DSCC-VA prior to listing as an approved source of supply for this appendix shall affirm that the manufacturer's product meets, for device classes Q and V, the requirements of MIL-PRF-38535 and the requirements herein.

A.3.7 Certificate of conformance. A certificate of conformance as required for device classes Q and V in MIL-PRF-38535 shall be provided with each lot of microcircuit die delivered to this drawing.

A.4 VERIFICATION

A.4.1 Sampling and inspection. For device classes Q and V, die sampling and inspection procedures shall be in accordance with MIL-PRF-38535 or as modified in the device manufacturer's Quality Management (QM) plan. The modifications in the QM plan shall not affect the form, fit, or function as described herein.

A.4.2 Screening. For device classes Q and V, screening shall be in accordance with MIL-PRF-38535, and as defined in the manufacturer's QM plan. As a minimum, it shall consist of:

- a. Wafer lot acceptance for class V product using the criteria defined in MIL-STD-883, method 5007.
- b. 100% wafer probe (see paragraph A.3.4 herein).
- c. 100% internal visual inspection to the applicable class Q or V criteria defined in MIL-STD-883, method 2010 or the alternate procedures allowed in MIL-STD-883, method 5004.

A.4.3 Conformance inspection.

A.4.3.1 Group E inspection. Group E inspection is required only for parts intended to be identified as radiation assured (see A.3.5 herein). RHA levels for device classes Q and V shall be as specified in MIL-PRF-38535. End point electrical testing of packaged die shall be as specified in table II herein. Group E tests and conditions are as specified in paragraphs 4.4.4, 4.4.4.1, 4.4.4.2, and 4.4.4.2.1 herein.

A.5 DIE CARRIER

A.5.1 Die carrier requirements. The requirements for the die carrier shall be accordance with the manufacturer's QM plan or as specified in the purchase order by the acquiring activity. The die carrier shall provide adequate physical, mechanical and electrostatic protection.

A.6 NOTES

A.6.1 Intended use. Microcircuit die conforming to this drawing are intended for use in microcircuits built in accordance with MIL-PRF-38535 or MIL-PRF-38534 for government microcircuit applications (original equipment), design applications, and logistics purposes.

A.6.2 Comments. Comments on this appendix should be directed to DSCC-VA, Columbus, Ohio, 43218-3990 or telephone (614)-692-0547.

A.6.3 Abbreviations, symbols, and definitions. The abbreviations, symbols, and definitions used herein are defined in MIL-PRF-38535 and MIL-HDBK-1331.

A.6.4 Sources of supply for device classes Q and V. Sources of supply for device classes Q and V are listed in QML-38535. The vendors listed within QML-38535 have submitted a certificate of compliance (see A.3.6 herein) to DSCC-VA and have agreed to this drawing.

| | | | |
|---|------------------|----------------------------|-------------------|
| STANDARD MICROCIRCUIT DRAWING DEFENSE SUPPLY CENTER COLUMBUS COLUMBUS, OHIO 43218-3990 | SIZE A | | 5962-99558 |
| | | REVISION LEVEL G | SHEET 19 |

APPENDIX A
APPENDIX A FORMS A PART OF SMD 5962-99558

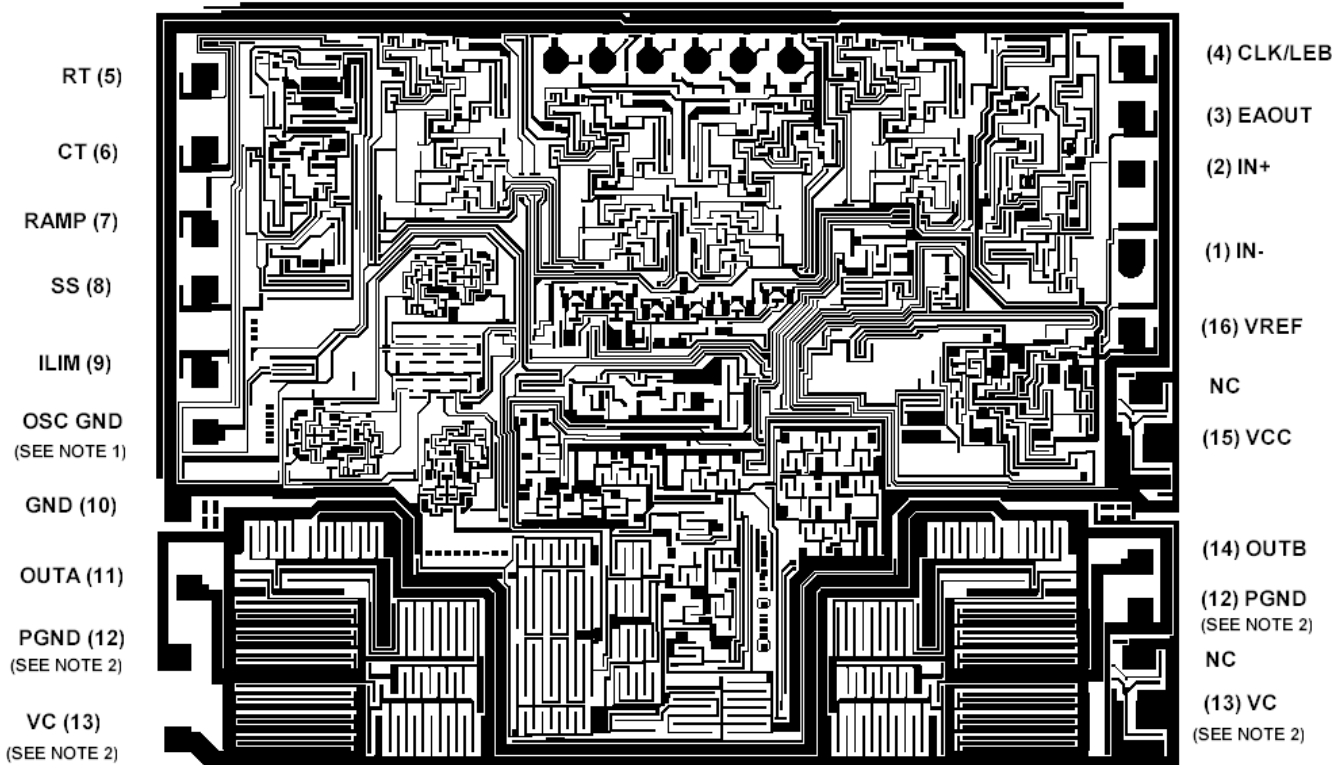

NOTE: Pad numbers reflect terminal numbers when placed in case outline X (see figure 1).

Die physical dimensions.

Die size: 4710 microns x 3570 microns.
Die thickness: 19 mils ± 1 mils.

Interface materials.

Top metallization: Al Si Cu 16.0 kÅ ± 2 kÅ
Backside metallization: None

Glassivation.

Type: PSG
Thickness: 8.0 kÅ ± 1.0 kÅ
Type: Si₃N₄
Thickness: 4.0 kÅ ± 0.5 kÅ

Substrate: DI (dielectric isolation)

Assembly related information.

Substrate potential: Unbiased

Special assembly instructions: Note 1. The oscillator ground (OSC GND) pad must be connected to ground.

Note 2. PGND and V_C each require 2 bond pad connections.

FIGURE A-1. Die bonding pad locations and electrical functions.

| | | | |
|---|------------------|---------------------|-------------------|
| STANDARD MICROCIRCUIT DRAWING DEFENSE SUPPLY CENTER COLUMBUS COLUMBUS, OHIO 43218-3990 | SIZE A | | 5962-99558 |
| | | REVISION LEVEL G | SHEET 20 |

STANDARD MICROCIRCUIT DRAWING BULLETIN

DATE: 08-12-09

Approved sources of supply for SMD 5962-99558 are listed below for immediate acquisition information only and shall be added to MIL-HDBK-103 and QML-38535 during the next revision. MIL-HDBK-103 and QML-38535 will be revised to include the addition or deletion of sources. The vendors listed below have agreed to this drawing and a certificate of compliance has been submitted to and accepted by DSCC-VA. This information bulletin is superseded by the next dated revision of MIL-HDBK-103 and QML-38535. DSCC maintains an online database of all current sources of supply at <http://www.dscclia.mil/Programs/Smcr/>.

| Standard microcircuit drawing PIN <u>1/</u> | Vendor CAGE number | Vendor similar PIN <u>2/</u> |
|---|--------------------|------------------------------|
| 5962F9955801QEC | 34371 | HS1-1825ARH-8 |
| 5962F9955801QXC | 34371 | HS9-1825ARH-8 |
| 5962F9955801Q2C | <u>3/</u> | HS4-1825ARH-8 |
| 5962R9955801TXC | <u>3/</u> | HS9-1825ARH-T |
| 5962F9955801VEC | 34371 | HS1-1825ARH-Q |
| 5962F9955801VXC | 34371 | HS9-1825ARH-Q |
| 5962F9955801V2C | <u>3/</u> | HS4-1825ARH-Q |
| 5962F9955801V9A | 34371 | HS0-1825ARH-Q |

- 1/ The lead finish shown for each PIN representing a hermetic package is the most readily available from the manufacturer listed for that part. If the desired lead finish is not listed contact the vendor to determine its availability.
- 2/ Caution. Do not use this number for item acquisition. Items acquired to this number may not satisfy the performance requirements of this drawing.
- 3/ Not available from an approved source of supply.

Vendor CAGE number

34371

Vendor name and address

Intersil Corporation
 1001 Murphy Ranch Road
 Milpitas, CA 95035-6803
 Point of contact: 1650 Robert J. Conlan Blvd.
 Palm Bay, FL 32905

The information contained herein is disseminated for convenience only and the Government assumes no liability whatsoever for any inaccuracies in the information bulletin.