

REVISIONS			
LTR	DESCRIPTION	DATE (YR-MO-DA)	APPROVED
A	Make change to peak pull-up current test as specified in table I. - ro	00-02-08	R. MONNIN
B	Make changes to paragraph 1.5. Paragraph 4.4.4.3 <u>Dose rate upset testing</u> deleted. Drawing updated to reflect current requirements. - gt	02-08-30	R. Monnin

REV																				
SHEET																				
REV	B	B	B	B	B	B	B	B	B	B	B	B								
SHEET	15	16	17	18	19	20	21	22	23	24	25	26								
REV STATUS				REV			B	B	B	B	B	B	B	B	B	B	B	B	B	B
OF SHEETS				SHEET			1	2	3	4	5	6	7	8	9	10	11	12	13	14
PMIC N/A	PREPARED BY RICK OFFICER						DEFENSE SUPPLY CENTER COLUMBUS COLUMBUS, OHIO 43216 http://www.dsccl.dla.mil													
STANDARD MICROCIRCUIT DRAWING THIS DRAWING IS AVAILABLE FOR USE BY ALL DEPARTMENTS AND AGENCIES OF THE DEPARTMENT OF DEFENSE AMSC N/A	CHECKED BY RAJESH PITHADIA																			
	APPROVED BY RAYMOND MONNIN						MICROCIRCUIT, LINEAR, RADIATION HARDENED, FULL BRIDGE N-CHANNEL FET DRIVER, MONOLITHIC SILICON													
	DRAWING APPROVAL DATE 00-01-12																			
	REVISION LEVEL B						SIZE A	CAGE CODE 67268	5962-99617											
						SHEET 1 OF 26														

1. SCOPE

1.1 Scope. This drawing documents three product assurance class levels consisting of high reliability (device classes Q and M), space application (device class V) and for appropriate satellite and similar applications (device class T). A choice of case outlines and lead finishes are available and are reflected in the Part or Identifying Number (PIN). When available, a choice of Radiation Hardness Assurance (RHA) levels are reflected in the PIN. For device class T, the user is encouraged to review the manufacturer's Quality Management (QM) plan as part of their evaluation of these parts and their acceptability in the intended application.

1.2 PIN. The PIN is as shown in the following example:

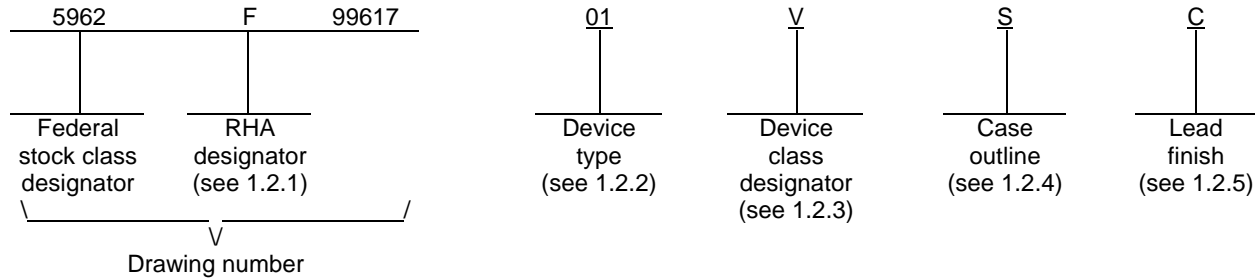

1.3 Absolute maximum ratings. 1/ 2/ 3/

Supply voltage (V _{DD} and V _{CC}).....	-0.3 V to 16 V
Logic I / O voltages.....	-0.3 V to V _{DD} +0.3 V
Voltage on AHS, BHS.....	-6.0 V (transient) to 80 V (-55°C to +125°C)
Voltage on ALS, BLS.....	-2.0 V (transient) to + 2.0 V (transient)
Voltage on AHB, BHB.....	V _{AHS} , BHS -0.3 V to V _{AHS} , BHS +V _{DD}
Voltage on ALO, BLO.....	V _{ALS} , BLS -0.3 V to V _{CC} +0.3 V
Voltage on AHO, BHO.....	V _{AHS} , BHS -0.3 V to V _{AHB} , BHB +0.3 V
Input current, HDEL and LDEL.....	-5 mA to 0 mA
Maximum power dissipation (P _D) (T _A ≤ +25°C).....	1.8 W
Junction temperature (T _J).....	+175°C
Storage temperature range.....	-55°C to +150°C
Lead temperature (soldering, 10 seconds).....	+300°C
Thermal resistance, junction-to-case (θ _{JC}).....	7°C/W
Thermal resistance, junction-to-ambient (θ _{JA}).....	80°C/W

1.4 Recommended operating conditions. 2/ 3/

Supply voltage (V _{DD} and V _{CC}).....	+12.0 V to +15.0 V
Voltage on ALS, BLS.....	-1.0 V to +1.0 V
Voltage on AHS, BHS.....	V _{AHS} , BHS + 5 V to V _{AHS} , BHS +15 V
Input current, HDEL and LDEL.....	-500 μA to -50 μA
Ambient operating temperature range (T _A).....	-55°C to +125°C

1.5 Radiation features:

Single Event Phenomenon (SEP) effective LET no upset.....	<70 MeV/mg/cm ²
Maximum total dose available (dose rate = 50 – 300 rad (Si) / s) :	
Device classes M, Q, or V.....	3 x 10 ⁵ Rads (Si)
Device class T.....	1 x 10 ⁵ Rads (Si)
Dose-rate latch-up.....	None 4/

- 1/ Stresses above the absolute maximum rating may cause permanent damage to the device. Extended operation at the maximum levels may degrade performance and affect reliability.
- 2/ Unless otherwise noted, all voltages are referenced to GND.
- 3/ The limits for the parameters specified herein shall apply over the full specified V_{CC} range and ambient temperature range of -55°C to +125°C unless otherwise noted.
- 4/ Guaranteed by process or design.

STANDARD MICROCIRCUIT DRAWING DEFENSE SUPPLY CENTER COLUMBUS COLUMBUS, OHIO 43216-5000	SIZE A		5962-99617
		REVISION LEVEL B	SHEET 3

2. APPLICABLE DOCUMENTS

2.1 Government specification, standards, and handbooks. The following specification, standards, and handbooks form a part of this drawing to the extent specified herein. Unless otherwise specified, the issues of these documents are those listed in the issue of the Department of Defense Index of Specifications and Standards (DoDISS) and supplement thereto, cited in the solicitation.

SPECIFICATION

DEPARTMENT OF DEFENSE

MIL-PRF-38535 - Integrated Circuits, Manufacturing, General Specification for.

STANDARDS

DEPARTMENT OF DEFENSE

MIL-STD-883 - Test Method Standard Microcircuits.
MIL-STD-1835 - Interface Standard Electronic Component Case Outlines.

HANDBOOKS

DEPARTMENT OF DEFENSE

MIL-HDBK-103 - List of Standard Microcircuit Drawings.
MIL-HDBK-780 - Standard Microcircuit Drawings.

(Unless otherwise indicated, copies of the specification, standards, and handbooks are available from the Standardization Document Order Desk, 700 Robbins Avenue, Building 4D, Philadelphia, PA 19111-5094.)

2.2 Order of precedence. In the event of a conflict between the text of this drawing and the references cited herein, the text of this drawing takes precedence. Nothing in this document, however, supersedes applicable laws and regulations unless a specific exemption has been obtained.

3. REQUIREMENTS

3.1 Item requirements. The individual item requirements for device classes Q, T and V shall be in accordance with MIL-PRF-38535 and as specified herein or as modified in the device manufacturer's Quality Management (QM) plan. The modification in the QM plan shall not affect the form, fit, or function as described herein. The individual item requirements for device class M shall be in accordance with MIL-PRF-38535, appendix A for non-JAN class level B devices and as specified herein.

3.1.1 Microcircuit die. For the requirements for microcircuit die, see appendix A to this document.

3.2 Design, construction, and physical dimensions. The design, construction, and physical dimensions shall be as specified in MIL-PRF-38535 and herein for device classes Q, T and V or MIL-PRF-38535, appendix A and herein for device class M.

3.2.1 Case outlines. The case outlines shall be in accordance with 1.2.4 herein.

3.2.2 Terminal connections. The terminal connections shall be as specified on figure 1.

3.2.3 Logic diagram. The logic diagram shall be as specified on figure 2.

3.2.4 Irradiation test circuit. The irradiation test connections shall be as specified in figure 3.

STANDARD MICROCIRCUIT DRAWING DEFENSE SUPPLY CENTER COLUMBUS COLUMBUS, OHIO 43216-5000	SIZE A		5962-99617
		REVISION LEVEL B	SHEET 4

3.3 Electrical performance characteristics and post irradiation parameter limits. Unless otherwise specified herein, the electrical performance characteristics and post irradiation parameter limits are as specified in table I and shall apply over the full ambient operating temperature range.

3.4 Electrical test requirements. The electrical test requirements shall be the subgroups specified in table IIA. The electrical tests for each subgroup are defined in table I.

3.5 Marking. The part shall be marked with the PIN listed in 1.2 herein. In addition, the manufacturer's PIN may also be marked as listed in MIL-HDBK-103. For packages where marking of the entire SMD PIN number is not feasible due to space limitations, the manufacturer has the option of not marking the "5962-" on the device. For RHA product using this option, the RHA designator shall still be marked. Marking for device classes Q, T and V shall be in accordance with MIL-PRF-38535. Marking for device class M shall be in accordance with MIL-PRF-38535, appendix A.

3.5.1 Certification/compliance mark. The certification mark for device classes Q, T and V shall be a "QML" or "Q" as required in MIL-PRF-38535. The compliance mark for device class M shall be a "C" as required in MIL-PRF-38535, appendix A.

3.6 Certificate of compliance. For device classes Q, T and V, a certificate of compliance shall be required from a QML-38535 listed manufacturer in order to supply to the requirements of this drawing (see 6.6.1 herein). For device class M, a certificate of compliance shall be required from a manufacturer in order to be listed as an approved source of supply in MIL-HDBK-103 (see 6.6.2 herein). The certificate of compliance submitted to DSCC-VA prior to listing as an approved source of supply for this drawing shall affirm that the manufacturer's product meets, for device classes Q, T and V, the requirements of MIL-PRF-38535 and herein or for device class M, the requirements of MIL-PRF-38535, appendix A and herein.

3.7 Certificate of conformance. A certificate of conformance as required for device classes Q, T and V in MIL-PRF-38535 or for device class M in MIL-PRF-38535, appendix A shall be provided with each lot of microcircuits delivered to this drawing.

3.8 Notification of change for device class M. For device class M, notification to DSCC-VA of change of product (see 6.2 herein) involving devices acquired to this drawing is required for any change as defined in MIL-PRF-38535, appendix A.

3.9 Verification and review for device class M. For device class M, DSCC, DSCC's agent, and the acquiring activity retain the option to review the manufacturer's facility and applicable required documentation. Offshore documentation shall be made available onshore at the option of the reviewer.

3.10 Microcircuit group assignment for device class M. Device class M devices covered by this drawing shall be in microcircuit group number 91 (see MIL-PRF-38535, appendix A).

STANDARD MICROCIRCUIT DRAWING DEFENSE SUPPLY CENTER COLUMBUS COLUMBUS, OHIO 43216-5000	SIZE A		5962-99617
		REVISION LEVEL B	SHEET 5

TABLE I. Electrical performance characteristics.

Test	Symbol	Conditions ^{1/} -55°C ≤ T _A ≤ +125°C unless otherwise specified	Group A subgroups	Device type	Limits		Unit
					Min	Max	
Supply currents and charge pumps section							
V _{DD} quiescent current	I _{DD}	-IN = 2.5 V, no load, other inputs = 0 V	1,2,3	01		13	mA
			M,D,P,L,R,F <u>2/</u>		1		
V _{DD} operating current	I _{DOD}	Outputs switching f = 500 kHz, no load	1,2,3	01		15	mA
			M,D,P,L,R,F <u>2/</u>		1		
V _{CC} quiescent current	I _{CC}	-IN = 2.5 V, no load, other inputs = 0 V	1,2,3	01		160	μA
			M,D,P,L,R,F <u>2/</u>		1		
V _{CC} operating current	I _{CCO}	f = 500 kHz, no load	1,2,3	01		7	mA
			M,D,P,L,R,F <u>2/</u>		1		
AHB, BHB quiescent current, Q pump output current	I _{AHB} , I _{BHB}	-IN = 2.5 V, no load, other inputs = 0 V, V _{DD} = V _{CC} = V _{AHB} = V _{BHB} = 12 V	1,2,3	01	-15		μA
			M,D,P,L,R,F <u>2/</u>		1	-15	
AHB, BHB operating current	I _{AHBO} , I _{BHBO}	f = 500 kHz, no load	1,2,3	01		5	mA
			M,D,P,L,R,F <u>2/</u>		1		
AHS, BHS, AHB, BHB leakage current	I _{HLK}	V _{AHS} = V _{BHS} = 95 V, V _{AHB} = V _{BHB} = 95 V	1,2,3	01		1	μA
			M,D,P,L,R,F <u>2/</u>		1		
AHB - AHS, BHB - BHS Q pump output voltage	V _{AHB} - V _{AHS} , V _{BHB} - V _{BHS}	No load	1,2,3	01	11.3	13.3	V
			M,D,P,L,R,F <u>2/</u>		1	11.3	

See footnotes at end of table.

STANDARD MICROCIRCUIT DRAWING DEFENSE SUPPLY CENTER COLUMBUS COLUMBUS, OHIO 43216-5000	SIZE A		5962-99617
		REVISION LEVEL B	SHEET 6

TABLE I. Electrical performance characteristics – Continued.

Test	Symbol	Conditions 1/ -55°C ≤ T _A ≤ +125°C unless otherwise specified	Group A subgroups	Device type	Limits		Unit
					Min	Max	
Input comparator pins: +INPUT, -INPUT, OUTPUT section							
Offset voltage	V _{OS}	Over common mode voltage range	1,2,3	01	-15	+15	mV
			M,D,P,L,R,F 2/		1	-15	
Input bias current	I _{IB}		1,2,3	01	0	2	μA
			M,D,P,L,R,F 2/		1	0	
Input offset current	I _{OS}		1,2,3	01	-2	+2	μA
			M,D,P,L,R,F 2/		1	-2	
Input common mode voltage range	CMVR		1,2,3	01	1	4.50	V
			M,D,P,L,R,F 2/		1	1	
OUTPUT high level output voltage	V _{OH}	+IN > -IN, I _{OH} = -250 μA	1,2,3	01	V _{DD} -0.4 V		V
			M,D,P,L,R,F 2/		1	V _{DD} -0.4 V	
OUTPUT low level output voltage	V _{OL}	+IN < -IN, I _{OL} = 250 μA	1,2,3			0.4	V
			M,D,P,L,R,F 2/		1		
High level output current	I _{OH}	V _{OUT} = 6 V	1,2,3	01		-1.5	mA
			M,D,P,L,R,F 2/		1		
Low level output current	I _{OL}	V _{OUT} = 6 V	1,2,3	01	2.5		mA
			M,D,P,L,R,F 2/		1	2.5	

See footnotes at end of table.

STANDARD MICROCIRCUIT DRAWING DEFENSE SUPPLY CENTER COLUMBUS COLUMBUS, OHIO 43216-5000	SIZE A		5962-99617
		REVISION LEVEL B	SHEET 7

TABLE I. Electrical performance characteristics – Continued.

Test	Symbol	Conditions 1/ -55°C ≤ T _A ≤ +125°C unless otherwise specified	Group A subgroups	Device type	Limits		Unit
					Min	Max	
INPUT pins: DIS section							
Low level input voltage	V _{IL}		1,2,3	01		0.8	V
			M,D,P,L,R,F 2/		1		
High level input voltage	V _{IH}		1,2,3	01	3.0		V
			M,D,P,L,R,F 2/		1	3.0	
Low level input current	I _{IL}	V _{IN} = 0 V	1,2,3	01	-160		μA
			M,D,P,L,R,F 2/		1	-160	
High level input current	I _{IH}	V _{IN} = 5 V	1,2,3	01	-150		μA
			M,D,P,L,R,F 2/		1	-150	
INPUT pins: HEN section							
Low level input voltage	V _{IL}		1,2,3	01		0.8	V
			M,D,P,L,R,F 2/		1		
High level input voltage	V _{IH}		1,2,3	01	3.0		V
			M,D,P,L,R,F 2/		1	3.0	
Low level input current	I _{IL}	V _{IN} = 0 V	1,2,3	01	-160		μA
			M,D,P,L,R,F 2/		1	-160	
High level input current	I _{IH}	V _{IN} = 5 V	1,2,3	01	-150		μA
			M,D,P,L,R,F 2/		1	-150	

See footnotes at end of table.

STANDARD MICROCIRCUIT DRAWING DEFENSE SUPPLY CENTER COLUMBUS COLUMBUS, OHIO 43216-5000	SIZE A		5962-99617
		REVISION LEVEL B	SHEET 8

TABLE I. Electrical performance characteristics – Continued.

Test	Symbol	Conditions 1/ -55°C ≤ T _A ≤ +125°C unless otherwise specified	Group A subgroups	Device type	Limits		Unit
					Min	Max	
Turn-on delay pins: LDEL and HDEL section							
LDEL, HDEL voltage	V _{HDEL} , V _{LDEL}	I _{HDEL} = I _{LDEL} = -100 μA	1,2,3	01	5.0	5.5	V
			M,D,P,L,R,F 2/		1	5.0	
Gate driver output pins; ALO, BLO AHO, and BHO section							
Low level output voltage	V _{OL}	I _{OUT} = 100 mA	1,2,3	01		1.4	V
			M,D,P,L,R,F 2/		1		
High level output voltage	V _{CC} - V _{OH}	I _{OUT} = -100 mA	1,2,3	01		1.6	V
			M,D,P,L,R,F 2/		1		
Peak pull-up current	+I _O	V _{OUT} = 0 V	1,2,3	01	0.4		A
			M,D,P,L,R,F 2/		1	0.4	
Peak pull-down current	-I _O	V _{OUT} = 12 V	1,2,3	01	0.4		A
			M,D,P,L,R,F 2/		1	0.4	
Under voltage, rising threshold	+UV		1,2,3	01	8.0	10.0	V
			M,D,P,L,R,F 2/		1	8.0	
Under voltage, falling threshold	-UV		1,2,3	01	7.5	9.5	V
			M,D,P,L,R,F 2/		1	7.5	
Under voltage, hysteresis	HYS		1,2,3	01	0.5	0.9	V
			M,D,P,L,R,F 2/		1	0.5	
Switching section							
Lower turn-off propagation delay (+IN / -IN to ALO)	t _{LPHL}	3/	9,10,11	01		450	ns
			M,D,P,L,R,F 2/		9		
Upper turn-off propagation delay (+IN / -IN to AHO)	t _{LPHL}	3/	9,10,11	01		1200	ns
			M,D,P,L,R,F 2/		9		

See footnotes at end of table.

STANDARD MICROCIRCUIT DRAWING DEFENSE SUPPLY CENTER COLUMBUS COLUMBUS, OHIO 43216-5000	SIZE A		5962-99617
		REVISION LEVEL B	SHEET 9

TABLE I. Electrical performance characteristics – Continued.

Test	Symbol	Conditions ^{1/} -55°C ≤ T _A ≤ +125°C unless otherwise specified	Group A subgroups	Device type	Limits		Unit
					Min	Max	
Switching section – Continued.							
Lower turn-off propagation delay (+IN / -IN to BLO)	t _{LPHL}	<u>3/</u>	9,10,11	01		1200	ns
			M,D,P,L,R,F <u>2/</u>		9		
Upper turn-off propagation delay (+IN / -IN to BHO)	t _{LPHL}	<u>3/</u>	9,10,11	01		500	ns
			M,D,P,L,R,F <u>2/</u>		9		
Lower turn-on propagation delay (+IN / -IN to BLO)	t _{LPLH}	<u>3/</u>	9,10,11	01		650	ns
			M,D,P,L,R,F <u>2/</u>		9		
Lower turn-on propagation delay (+IN / -IN to BHO)	t _{HPLH}	<u>3/</u>	9,10,11	01		1200	ns
			M,D,P,L,R,F <u>2/</u>		9		
Lower turn-on propagation delay (+IN / -IN to ALO)	t _{LPLH}	<u>3/</u>	9,10,11	01		1200	ns
			M,D,P,L,R,F <u>2/</u>		9		
Upper turn-on propagation delay (+IN / -IN to AHO)	t _{HPLH}	<u>3/</u>	9,10,11	01		600	ns
			M,D,P,L,R,F <u>2/</u>		9		
Rise time	t _R	<u>3/</u>	9,10,11	01		65	ns
			M,D,P,L,R,F <u>2/</u>		9		
Fall time	t _F	<u>3/</u>	9,10,11	01		60	ns
			M,D,P,L,R,F <u>2/</u>		9		
Turn-on input pulse width	t _{PWIN-ON}	<u>3/</u>	9,10,11	01	700		ns
			M,D,P,L,R,F <u>2/</u>		9	700	
Turn-off input pulse width	t _{PWIN-OFF}	<u>3/</u>	9,10,11	01	700		ns
			M,D,P,L,R,F <u>2/</u>		9	700	
Disable turn-off propagation delay (DIS – lower outputs)	t _{DISLOW}	<u>3/</u>	9,10,11	01		500	ns
			M,D,P,L,R,F <u>2/</u>		9		

See footnotes at end of table.

STANDARD MICROCIRCUIT DRAWING DEFENSE SUPPLY CENTER COLUMBUS COLUMBUS, OHIO 43216-5000	SIZE A		5962-99617
		REVISION LEVEL B	SHEET 10

TABLE I. Electrical performance characteristics – Continued.

Test	Symbol	Conditions ^{1/} -55°C ≤ T _A ≤ +125°C unless otherwise specified	Group A subgroups	Device type	Limits		Unit
					Min	Max	
Switching section – Continued.							
Disable turn-off propagation delay (DIS – upper outputs)	t _{DISHIGH}	^{3/}	9,10,11	01		450	ns
			M,D,P,L,R,F ^{2/}		9	450	
Disable to lower turn-on propagation delay (DIS – ALO and BLO)	t _{DPLHL}	^{3/}	9,10,11	01		750	ns
			M,D,P,L,R,F ^{2/}		9	750	
Refresh pulse width (ALO and BLO)	t _{REF-PW}	^{3/}	9,10,11	01		450	ns
			M,D,P,L,R,F ^{2/}		9	450	
Disable to upper enable (DIS – AHO and BHO)	t _{UEN}	^{3/}	9,10,11	01		1250	ns
			M,D,P,L,R,F ^{2/}		9	1250	
HEN-AHO, BHO turn-off, propagation delay	t _{HEN- PHL}	^{3/}	9,10,11	01		450	ns
			M,D,P,L,R,F ^{2/}		9	450	
HEN-AHO, BHO turn-on, propagation delay	t _{HEN- PLH}	^{3/}	9,10,11	01		500	ns
			M,D,P,L,R,F ^{2/}		9	500	

^{1/} Unless otherwise specified, V_{DD} = V_{CC} = V_{AHB} = V_{BHB} = 12 V and V_{SS} = V_{ALS} = V_{BLS} = V_{AHS} = V_{BHS} = 0 V.

^{2/} Devices supplied to this drawing meet all levels M, D, P, L, R, and F for device classes M, Q, and V and for device class T, will meet levels M, D, P, L, and R of irradiation. However, this device is only tested at the "F" level for device classes M, Q, and V and at the "R" level for device class T (see 1.5 herein). Pre and post irradiation values are identical unless otherwise specified in table I. When performing post irradiation electrical measurements for any RHA level, T_A = +25°C.

^{3/} R_{HDEL} = R_{LDEL} = 10 kΩ and C_L = 1000 pF.

STANDARD MICROCIRCUIT DRAWING DEFENSE SUPPLY CENTER COLUMBUS COLUMBUS, OHIO 43216-5000	SIZE A		5962-99617
		REVISION LEVEL B	SHEET 11

Device type	01
Case outline	S
Terminal number	Terminal symbol
1	BHB
2	HEN
3	DIS
4	V _{SS}
5	OUT
6	+IN
7	-IN
8	HDEL
9	LDEL
10	AHB
11	AHO
12	AHS
13	ALO
14	ALS
15	V _{CC}
16	V _{DD}
17	BLS
18	BLO
19	BHS
20	BHO

FIGURE 1. Terminal connections.

STANDARD MICROCIRCUIT DRAWING DEFENSE SUPPLY CENTER COLUMBUS COLUMBUS, OHIO 43216-5000	SIZE A		5962-99617
		REVISION LEVEL B	SHEET 12

PIN number	SYMBOL	DESCRIPTION
1	BHB	B high-side bootstrap supply. External bootstrap diode and capacitor are required. Connect cathode of bootstrap diode and positive side of bootstrap capacitor to this pin. Internal charge pump supplies 15 μ A out of this pin to maintain bootstrap supply. Internal circuitry clamps the bootstrap supply to approximately 15.0 V maximum.
2	HEN	High-side enable input. Logic level input that when low overrides +IN/-IN. (Pins 6 and 7) to put AHO and BHO drivers (pins 11 and 20) in low output state. When HEN is high AHO and BHO are controlled by +IN/-IN inputs. The pin can be driven by signal levels of 0 V to 15 V (no greater than V_{DD}). An internal 100 μ A pull-up to V_{DD} will hold HEN high, so no connection is required if high-side and low-side outputs are to be controlled by +IN/-IN inputs.
3	DIS	Disable input. Logic level input that when taken high sets all four outputs low. DIS high overrides all other inputs. When DIS is taken low the outputs are controlled by the other inputs. The pin can be driven by signal levels of 0 V to 15 V (no greater than V_{DD}). An internal 100 μ A pull-up to V_{DD} will hold DIS high if this pin is not driven.
4	V_{SS}	Chip negative supply, generally will be ground.
5	OUT	Output of the input control comparator. This output can be used for feedback and hysteresis.
6	+IN	Noninverting input of control comparator. This pin can only be driven by signal levels of 0 V to 4.5 V. If +IN is greater than -IN (pin 7), than ALO and BHO are low level outputs and BLO and AHO are high level outputs. If +IN is less than -IN than ALO and BHO are high level outputs and BLO and AHO are low level outputs. DIS (pin 3) high level will override +IN/-IN control for all outputs. HEN (pin 2) low level will override +IN/-IN control of AHO and BHO. When switching in four quadrant mode, dead time in a half bridge leg is controlled by HDEL and LDEL (pins 8 and 9).
7	-IN	Inverting input of control comparator. This pin can only be driven by signal levels of 0 V to 4.5 V. See +IN (pin 6) description.
8	HDEL	High-side turn-on delay. Connect resistor from this pin to V_{SS} to set timing current that defines the turn-on delay of both high-side drivers. The low-side drivers turn-off with no adjustable delay, so the HDEL resistor guarantees no shoot-through by delaying the turn-on of the high-side drivers. HDEL reference voltage is approximately 5.2 V.
9	LDEL	Low-side turn-on delay. Connect resistor from this pin to V_{SS} to set timing current that defines the turn-on delay of both low-side drivers. The high-side drivers turn-off with no adjustable delay, so the LDEL resistor guarantees no shoot-through by delaying the turn-on of the low-side drivers. LDEL reference voltage is approximately 5.2 V.

FIGURE 1. Terminal connections – Continued.

STANDARD MICROCIRCUIT DRAWING DEFENSE SUPPLY CENTER COLUMBUS COLUMBUS, OHIO 43216-5000	SIZE A		5962-99617
		REVISION LEVEL B	SHEET 13

PIN number	SYMBOL	DESCRIPTION
10	AHB	A high-side bootstrap supply. External bootstrap diode and capacitor are required. Connect cathode of bootstrap diode and positive side of bootstrap capacitor to this pin. Internal charge pump supplies 15 μ A out of this pin to maintain bootstrap supply. Internal circuitry clamps the supply to approximately 15.0 V.
11	AHO	A high-side output. Connect to gate of A high-side power MOSFET.
12	AHS	A high-side source connection. Connect to source of A high-side power MOSFET. Connect negative side of bootstrap capacitor to this pin.
13	ALO	A low-side output. Connect to gate of A low-side power MOSFET.
14	ALS	A low-side source connection. Connection to source of A low-side power MOSFET.
15	V _{CC}	Positive supply to gate drivers. Must be same potential as V _{DD} (pin 16). Connect to anode of two bootstrap diodes.
16	V _{DD}	Positive supply to lower gate drivers. Must be same potential as V _{CC} (pin 15). De-couple this pin to V _{SS} (pin 4).
17	BLS	B low-side. Source connection. Connect to source of B low-side power MOSFET.
18	BLO	B low-side output. Connect to gate of B low-side power MOSFET.
19	BHS	B high-side source connection. Connect to source of B high-side power MOSFET. Connect negative side of bootstrap capacitor to this pin.
20	BHO	B high-side output. Connect to gate of B high-side power MOSFET.

FIGURE 1. Terminal connections – Continued.

STANDARD MICROCIRCUIT DRAWING DEFENSE SUPPLY CENTER COLUMBUS COLUMBUS, OHIO 43216-5000	SIZE A		5962-99617
		REVISION LEVEL B	SHEET 14

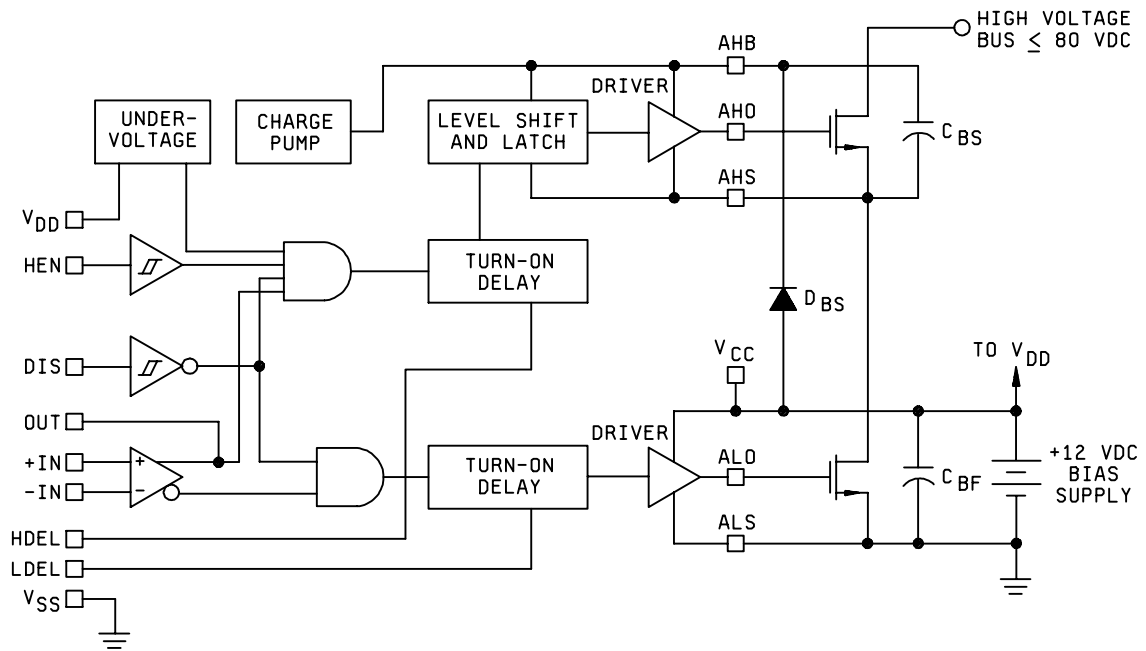

FIGURE 2. Logic diagram.

**STANDARD
MICROCIRCUIT DRAWING**
DEFENSE SUPPLY CENTER COLUMBUS
COLUMBUS, OHIO 43216-5000

SIZE
A

5962-99617

REVISION LEVEL
B

SHEET

15

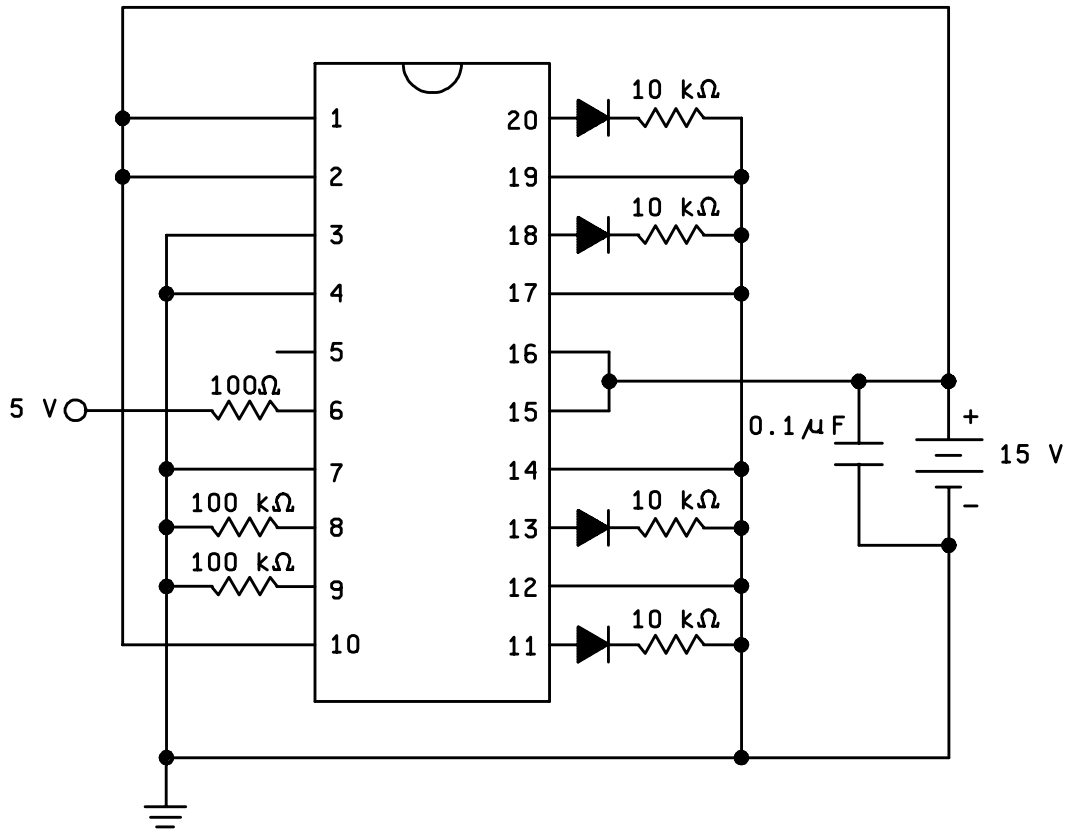

FIGURE 3. Irradiation exposure circuit.

STANDARD MICROCIRCUIT DRAWING DEFENSE SUPPLY CENTER COLUMBUS COLUMBUS, OHIO 43216-5000	SIZE A		5962-99617
		REVISION LEVEL B	SHEET 16

4. QUALITY ASSURANCE PROVISIONS

4.1 Sampling and inspection. For device classes Q, and V, sampling and inspection procedures shall be in accordance with MIL-PRF-38535 or as modified in the device manufacturer's Quality Management (QM) plan, including screening (4.2), qualification (4.3), and conformance inspection (4.4). The modification in the QM plan shall not affect the form, fit, or function as described herein. For device class T, sampling and inspection procedures shall be in accordance with MIL-PRF-38535 and the device manufacturer's QM plan, including screening, qualification, and conformance inspection. The performance envelope and reliability information shall be as specified in the manufacturer's QM plan. For device class M, sampling and inspection procedures shall be in accordance with MIL-PRF-38535, appendix A.

4.2 Screening. For device classes Q and V, screening shall be in accordance with MIL-PRF-38535, and shall be conducted on all devices prior to qualification and technology conformance inspection. For device class M, screening shall be in accordance with method 5004 of MIL-STD-883, and shall be conducted on all devices prior to quality conformance inspection. For device class T, screening shall be in accordance with the device manufacturer's Quality Management (QM) plan, and shall be conducted on all devices prior to qualification and technology conformance inspection.

4.2.1 Additional criteria for device class M.

- a. Burn-in test, method 1015 of MIL-STD-883.
 - (1) Test condition A, B, C, or D. The test circuit shall be maintained by the manufacturer under document revision level control and shall be made available to the preparing or acquiring activity upon request. The test circuit shall specify the inputs, outputs, biases, and power dissipation, as applicable, in accordance with the intent specified in test method 1015.
 - (2) $T_A = +125^{\circ}\text{C}$, minimum.
- b. Interim and final electrical test parameters shall be as specified in table IIA herein.

4.2.2 Additional criteria for device classes Q, T and V.

- a. The burn-in test duration, test condition and test temperature, or approved alternatives shall be as specified in the device manufacturer's QM plan in accordance with MIL-PRF-38535. The burn-in test circuit shall be maintained under document revision level control of the device manufacturer's Technology Review Board (TRB) in accordance with MIL-PRF-38535 and shall be made available to the acquiring or preparing activity upon request. The test circuit shall specify the inputs, outputs, biases, and power dissipation, as applicable, in accordance with the intent specified in test method 1015 of MIL-STD-883.
- b. Interim and final electrical test parameters shall be as specified in table IIA herein.
- c. Additional screening for device class V beyond the requirements of device class Q shall be as specified in MIL-PRF-38535, appendix B or as modified in the device manufacturer's Quality Management (QM) plan.

4.3 Qualification inspection for device classes Q, T and V. Qualification inspection for device classes Q and V shall be in accordance with MIL-PRF-38535. Qualification inspection for device class T shall be in accordance with the device manufacturer's Quality Management (QM) plan. Inspections to be performed shall be those specified in MIL-PRF-38535 and herein for groups A, B, C, D, and E inspections (see 4.4.1 through 4.4.4).

4.3.1 Electrostatic discharge sensitivity (ESDS) qualification inspection. ESDS testing shall be performed in accordance with MIL-STD-883, method 3015. ESDS testing shall be measured only for initial qualification and after process or design changes which may affect ESDS classification.

STANDARD MICROCIRCUIT DRAWING DEFENSE SUPPLY CENTER COLUMBUS COLUMBUS, OHIO 43216-5000	SIZE A		5962-99617
		REVISION LEVEL B	SHEET 17

TABLE IIA. Electrical test requirements.

Test requirements	Subgroups (in accordance with MIL-STD-883, method 5005, table I)	Subgroups (in accordance with MIL-PRF-38535, table III)		
	Device class M	Device class Q	Device class V	Device class T
Interim electrical parameters (see 4.2)	1	1	1	As specified in QM plan
Final electrical parameters (see 4.2)	1,2,3,9,10,11 <u>1/</u>	1,2,3,9, <u>1/</u> 10,11	1,2,3, <u>2/ 3/</u> 9,10,11	
Group A test requirements (see 4.4)	1,2,3,9,10,11	1,2,3,9,10,11	1,2,3,9,10,11	
Group C end-point electrical parameters (see 4.4)	1,2,3,9,10,11	1,2,3,9,10,11	1,2,3,9, <u>3/</u> 10,11	
Group D end-point electrical parameters (see 4.4)	1	1	1	
Group E end-point electrical parameters (see 4.4)	1,9	1,9	1,9	

1/ PDA applies to subgroups 1.

2/ PDA applies to subgroups 1, 9, and Δ's.

3/ Delta limits as specified in table IIB herein shall be required where specified, and the delta values shall be computed with reference to the zero hour electrical parameters (see table I).

TABLE IIB. Burn-in and operating life test, Delta parameters (+25°C).

Parameters <u>1/</u>	Delta limits
V _{DD} quiescent current (I _{DD})	±300 μA
AHS, BHS, AHB, BHB leakage current (I _{H_{LK}})	±100 nA

1/ These parameters shall be recorded before and after the required burn-in and life test to determine delta limits.

STANDARD MICROCIRCUIT DRAWING DEFENSE SUPPLY CENTER COLUMBUS COLUMBUS, OHIO 43216-5000	SIZE A		5962-99617
		REVISION LEVEL B	SHEET 18

4.4 Conformance inspection. Technology conformance inspection for classes Q and V shall be in accordance with MIL-PRF-38535 including groups A, B, C, D, and E inspections and as specified herein. Quality conformance inspection for device class M shall be in accordance with MIL-PRF-38535, appendix A and as specified herein. Inspections to be performed for device class M shall be those specified in method 5005 of MIL-STD-883 and herein for groups A, B, C, D, and E inspections (see 4.4.1 through 4.4.4). Technology conformance inspection for class T shall be in accordance with the device manufacturer's quality management (QM) plan.

4.4.1 Group A inspection.

- a. Tests shall be as specified in table IIA herein.
- b. Subgroups 4, 5, 6, 7, and 8 in table I, method 5005 of MIL-STD-883 shall be omitted.

4.4.2 Group C inspection. The group C inspection end-point electrical parameters shall be as specified in table IIA herein.

4.4.2.1 Additional criteria for device class M. Steady-state life test conditions, method 1005 of MIL-STD-883:

- a. Test condition A, B, C, or D. The test circuit shall be maintained by the manufacturer under document revision level control and shall be made available to the preparing or acquiring activity upon request. The test circuit shall specify the inputs, outputs, biases, and power dissipation, as applicable, in accordance with the intent specified in test method 1005 of MIL-STD-883.
- b. $T_A = +125^\circ\text{C}$, minimum.
- c. Test duration: 1,000 hours, except as permitted by method 1005 of MIL-STD-883.

4.4.2.2 Additional criteria for device classes Q, T and V. The steady-state life test duration, test condition and test temperature, or approved alternatives shall be as specified in the device manufacturer's QM plan in accordance with MIL-PRF-38535. The test circuit shall be maintained under document revision level control by the device manufacturer's TRB in accordance with MIL-PRF-38535 and shall be made available to the acquiring or preparing activity upon request. The test circuit shall specify the inputs, outputs, biases, and power dissipation, as applicable, in accordance with the intent specified in test method 1005 of MIL-STD-883.

4.4.3 Group D inspection. The group D inspection end-point electrical parameters shall be as specified in table IIA herein.

4.4.4 Group E inspection. Group E inspection is required only for parts intended to be marked as radiation hardness assured (see 3.5 herein). RHA levels for device classes M, Q and V shall be as specified in MIL-PRF-38535 and the end-point electrical parameters shall be as specified in table IIA herein. For device class T, the RHA requirements shall be in accordance with the Class T Radiation Requirements of MIL-PRF-38535. The end-point electrical parameters for class T devices shall be as specified in Table I, Group A subgroups, or as modified in the QM plan.

4.4.4.1 Total dose irradiation testing. Total dose irradiation testing shall be performed in accordance with MIL-STD-883 method 1019, condition A, and as specified herein. For device class T, the total dose requirements shall be in accordance with the class T radiation requirements of MIL-PRF-38535 (see 1.5 herein).

4.4.4.1.1 Accelerated aging testing. Accelerated aging testing shall be performed on all devices requiring a RHA level greater than 5k rads (Si). The post-anneal end-point electrical parameter limits shall be as specified in table I herein and shall be the pre-irradiation end-point electrical parameter limits at $25^\circ\text{C} \pm 5^\circ\text{C}$. Testing shall be performed at initial qualification and after any design or process changes which may affect the RHA response of the device.

4.4.4.2 Dose-rate latch-up testing. Dose rate induced latchup testing shall be performed in accordance with test method 1020 of MIL-STD-883 and as specified herein (see 1.5 herein). Tests shall be performed on devices, SEC, or approved test structures at technology qualification and after any design or process changes which may effect the RHA capability of the process.

STANDARD MICROCIRCUIT DRAWING DEFENSE SUPPLY CENTER COLUMBUS COLUMBUS, OHIO 43216-5000	SIZE A		5962-99617
		REVISION LEVEL B	SHEET 19

4.4.4.3 Single event phenomena (SEP). When specified in the purchase order or contract SEP testing shall be required on class T and V devices (see 1.5 herein). SEP testing shall be performed on a technology process on the Standard Evaluation Circuit (SEC) or alternate SEP test vehicle as approved by the qualifying activity at initial qualification and after any design or process changes which may affect the upset or latchup characteristics. The recommended test conditions for SEP are as follows:

- a. The ion beam angle of incidence shall be between normal to the die surface and 60° to the normal, inclusive (i.e. 0° ≤ angle ≤ 60°). No shadowing of the ion beam due to fixturing or package related effects is allowed.
- b. The fluence shall be ≥ 100 errors or ≥ 10⁶ ions/cm².
- c. The flux shall be between 10² and 10⁵ ions/cm²/s. The cross-section shall be verified to be flux independent by measuring the cross-section at two flux rates which differ by at least an order of magnitude.
- d. The particle range shall be ≥ 20 micron in silicon.
- e. The test temperature shall be +25°C and the maximum rated operating temperature ±10°C.
- f. Bias conditions shall be defined by the manufacturer for the latchup measurements.
- g. Test four devices with zero failures.

4.5 Methods of inspection. Methods of inspection shall be specified as follows:

4.5.1 Voltage and current. Unless otherwise specified, all voltages given are referenced to the microcircuit GND terminal. Currents given are conventional current and positive when flowing into the referenced terminal.

5. PACKAGING

5.1 Packaging requirements. The requirements for packaging shall be in accordance with MIL-PRF-38535 for device classes Q, T and V or MIL-PRF-38535, appendix A for device class M.

6. NOTES

6.1 Intended use. Microcircuits conforming to this drawing are intended for use for Government microcircuit applications (original equipment), design applications, and logistics purposes.

6.1.1 Replaceability. Microcircuits covered by this drawing will replace the same generic device covered by a contractor prepared specification or drawing.

6.1.2 Substitutability. Device class Q devices will replace device class M devices.

6.2 Configuration control of SMD's. All proposed changes to existing SMD's will be coordinated with the users of record for the individual documents. This coordination will be accomplished using DD Form 1692, Engineering Change Proposal.

STANDARD MICROCIRCUIT DRAWING DEFENSE SUPPLY CENTER COLUMBUS COLUMBUS, OHIO 43216-5000	SIZE A		5962-99617
		REVISION LEVEL B	SHEET 20

6.3 Record of users. Military and industrial users should inform Defense Supply Center Columbus when a system application requires configuration control and which SMD's are applicable to that system. DSCC will maintain a record of users and this list will be used for coordination and distribution of changes to the drawings. Users of drawings covering microelectronic devices (FSC 5962) should contact DSCC-VA, telephone (614) 692-0544.

6.4 Comments. Comments on this drawing should be directed to DSCC-VA , Columbus, Ohio 43216-5000, or telephone (614) 692-0547.

6.5 Abbreviations, symbols, and definitions. The abbreviations, symbols, and definitions used herein are defined in MIL-PRF-38535 and MIL-HDBK-1331.

6.6 Sources of supply.

6.6.1 Sources of supply for device classes Q, T and V. Sources of supply for device classes Q, T and V are listed in QML-38535. The vendors listed in QML-38535 have submitted a certificate of compliance (see 3.6 herein) to DSCC-VA and have agreed to this drawing.

6.6.2 Approved sources of supply for device class M. Approved sources of supply for class M are listed in MIL-HDBK-103. The vendors listed in MIL-HDBK-103 have agreed to this drawing and a certificate of compliance (see 3.6 herein) has been submitted to and accepted by DSCC-VA.

6.7 Additional information. When applicable, a copy of the following additional data shall be maintained and available from the device manufacturer:

- a. RHA upset levels.
- b. Test conditions (SEP).
- c. Number of upsets (SEP).
- d. Number of transients (SEP).
- e. Occurrence of latchup (SEP).

STANDARD MICROCIRCUIT DRAWING DEFENSE SUPPLY CENTER COLUMBUS COLUMBUS, OHIO 43216-5000	SIZE A		5962-99617
		REVISION LEVEL B	SHEET 21

APPENDIX A
APPENDIX A FORMS A PART OF SMD 5962-99617

10. SCOPE

10.1 Scope. This appendix establishes minimum requirements for microcircuit die to be supplied under the Qualified Manufacturers List (QML) Program. QML microcircuit die meeting the requirements of MIL-PRF-38535 and the manufacturers approved QML plan for use in monolithic microcircuits, multi-chip modules (MCMs), hybrids, electronic modules, or devices using chip and wire designs in accordance with MIL-PRF-38534 are specified herein. Two product assurance classes consisting of military high reliability (device class Q) and space application (device Class V) are reflected in the Part or Identification Number (PIN). When available a choice of Radiation Hardness Assurance (RHA) levels are reflected in the PIN.

10.2 PIN. The PIN is as shown in the following example:

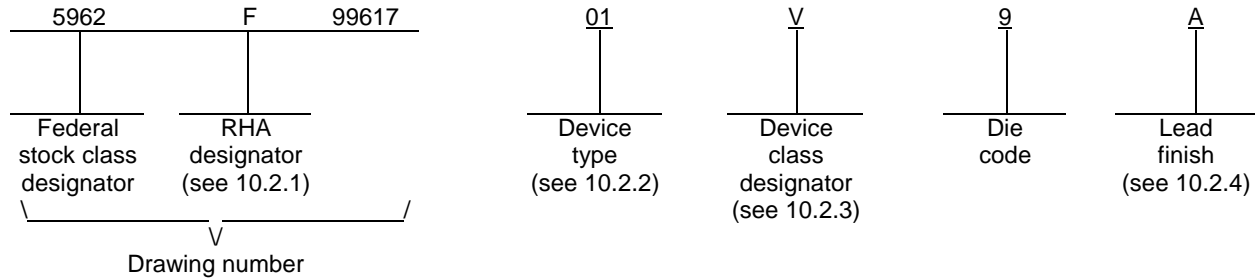

10.2.1 RHA designator. Device classes Q and V RHA identified die shall meet the MIL-PRF-38535 specified RHA levels. A dash (-) indicates a non-RHA die.

10.2.2 Device type(s). The device type(s) shall identify the circuit function as follows:

Device type	Generic number	Circuit function
01	HS-4080ARH	Radiation hardened DI full bridge N-channel FET driver

10.2.3 Device class designator.

Device class	Device requirements documentation
Q or V	Certification and qualification to the die requirements of MIL-PRF-38535

10.2.4. Die Details. The die details designation shall be a unique letter which designates the die's physical dimensions, bonding pad location(s) and related electrical function(s), interface materials, and other assembly related information, for each product and variant supplied to this appendix.

10.2.4.1 Die physical dimensions.

Die type	Figure number
01	A-1

STANDARD MICROCIRCUIT DRAWING DEFENSE SUPPLY CENTER COLUMBUS COLUMBUS, OHIO 43216-5000	SIZE A		5962-99617
		REVISION LEVEL B	SHEET 22

APPENDIX A
APPENDIX A FORMS A PART OF SMD 5962-99617

10.2.4.2. Die bonding pad locations and electrical functions.

Die type	Figure number
01	A-1

10.2.4.3. Interface materials.

Die type	Figure number
01	A-1

10.2.4.4. Assembly related information.

Die type	Figure number
01	A-1

10.3. Absolute maximum ratings. See paragraph 1.3 within the body of this drawing for details.

10.4 Recommended operating conditions. See paragraph 1.4 within the body of this drawing for details.

20. APPLICABLE DOCUMENTS.

20.1 Government specifications, standards, and handbooks. Unless otherwise specified, the following specification, standard, and handbook of the issue listed in that issue of the Department of Defense Index of Specifications and Standards specified in the solicitation, form a part of this drawing to the extent specified herein.

SPECIFICATION

DEPARTMENT OF DEFENSE

MIL-PRF-38535 - Integrated Circuits, Manufacturing, General Specification for.

STANDARDS

DEPARTMENT OF DEFENSE

MIL-STD-883 - Test Method Standard Microcircuits.

HANDBOOK

DEPARTMENT OF DEFENSE

MIL-HDBK-103 - List of Standard Microcircuit Drawings.

(Copies of the specification, standard, and handbook required by manufacturers in connection with specific acquisition functions should be obtained from the contracting activity or as directed by the contracting activity).

20.2. Order of precedence. In the event of a conflict between the text of this drawing and the references cited herein, the text of this drawing shall take precedence.

STANDARD MICROCIRCUIT DRAWING DEFENSE SUPPLY CENTER COLUMBUS COLUMBUS, OHIO 43216-5000	SIZE A		5962-99617
		REVISION LEVEL B	SHEET 23

APPENDIX A
APPENDIX A FORMS A PART OF SMD 5962-99617

30. REQUIREMENTS

30.1 Item requirements. The individual item requirements for device classes Q and V shall be in accordance with MIL-PRF-38535 and as specified herein or as modified in the device manufacturer's Quality Management (QM) plan. The modification in the QM plan shall not effect the form, fit or function as described herein.

30.2 Design, construction and physical dimensions. The design, construction and physical dimensions shall be as specified in MIL-PRF-38535 and the manufacturer's QM plan, for device classes Q and V and herein.

30.2.1 Die physical dimensions. The die physical dimensions shall be as specified in 10.2.4.1 and on figure A-1.

30.2.2 Die bonding pad locations and electrical functions. The die bonding pad locations and electrical functions shall be as specified in 10.2.4.2 and on figure A-1.

30.2.3 Interface materials. The interface materials for the die shall be as specified in 10.2.4.3 and on figure A-1.

30.2.4 Assembly related information. The assembly related information shall be as specified in 10.2.4.4 and figure A-1.

30.2.5 Radiation exposure circuit. The radiation exposure circuit shall be as defined within paragraph 3.2.4 of the body of this document.

30.3 Electrical performance characteristics and post-irradiation parameter limits. Unless otherwise specified herein, the electrical performance characteristics and post-irradiation parameter limits are as specified in table I of the body of this document.

30.4 Electrical test requirements. The wafer probe test requirements shall include functional and parametric testing sufficient to make the packaged die capable of meeting the electrical performance requirements in table I.

30.5 Marking. As a minimum, each unique lot of die, loaded in single or multiple stack of carriers, for shipment to a customer, shall be identified with the wafer lot number, the certification mark, the manufacturer's identification and the PIN listed in 10.2 herein. The certification mark shall be a "QML" or "Q" as required by MIL-PRF-38535.

30.6 Certification of compliance. For device classes Q and V, a certificate of compliance shall be required from a QML-38535 listed manufacturer in order to supply to the requirements of this drawing (see 60.4 herein). The certificate of compliance submitted to DSCC-VA prior to listing as an approved source of supply for this appendix shall affirm that the manufacturer's product meets, for device classes Q and V, the requirements of MIL-PRF-38535 and the requirements herein.

30.7 Certificate of conformance. A certificate of conformance as required for device classes Q and V in MIL-PRF-38535 shall be provided with each lot of microcircuit die delivered to this drawing.

STANDARD MICROCIRCUIT DRAWING DEFENSE SUPPLY CENTER COLUMBUS COLUMBUS, OHIO 43216-5000	SIZE A		5962-99617
		REVISION LEVEL B	SHEET 24

APPENDIX A
APPENDIX A FORMS A PART OF SMD 5962-99617

40. QUALITY ASSURANCE PROVISIONS

40.1 Sampling and inspection. For device classes Q and V, die sampling and inspection procedures shall be in accordance with MIL-PRF-38535 or as modified in the device manufacturer's Quality Management (QM) plan. The modifications in the QM plan shall not effect the form, fit or function as described herein.

40.2 Screening. For device classes Q and V, screening shall be in accordance with MIL-PRF-38535, and as defined in the manufacturer's QM plan. As a minimum it shall consist of:

- a) Wafer lot acceptance for Class V product using the criteria defined within MIL-STD-883 test method 5007.
- b) 100% wafer probe (see paragraph 30.4).
- c) 100% internal visual inspection to the applicable class Q or V criteria defined within MIL-STD-883 test method 2010 or the alternate procedures allowed within MIL-STD-883 test method 5004.

40.3 Conformance inspection.

40.3.1 Group E inspection. Group E inspection is required only for parts intended to be identified as radiation assured (see 30.5 herein). RHA levels for device classes Q and V shall be as specified in MIL-PRF-38535. End point electrical testing of packaged die shall be as specified in table IIA herein. Group E tests and conditions are as specified within paragraphs 4.4.4.1, 4.4.4.1.1, 4.4.4.2, 4.4.4.3, and 4.4.4.4.

50. DIE CARRIER

50.1 Die carrier requirements. The requirements for the die carrier shall be accordance with the manufacturer's QM plan or as specified in the purchase order by the acquiring activity. The die carrier shall provide adequate physical, mechanical and electrostatic protection.

60 NOTES

60.1 Intended use. Microcircuit die conforming to this drawing are intended for use in microcircuits built in accordance with MIL-PRF-38535 or MIL-PRF-38534 for government microcircuit applications (original equipment), design applications and logistics purposes.

60.2 Comments. Comments on this appendix should be directed to DSCC-VA, Columbus, Ohio, 43216-5000 or telephone (614)-692-0536.

60.3 Abbreviations, symbols and definitions. The abbreviations, symbols, and definitions used herein are defined within MIL-PRF-38535 and MIL-STD-1331.

60.4 Sources of supply for device classes Q and V. Sources of supply for device classes Q and V are listed in QML-38535. The vendors listed within QML-38535 have submitted a certificate of compliance (see 30.6 herein) to DSCC-VA and have agreed to this drawing.

STANDARD MICROCIRCUIT DRAWING DEFENSE SUPPLY CENTER COLUMBUS COLUMBUS, OHIO 43216-5000	SIZE A		5962-99617
		REVISION LEVEL B	SHEET 25

APPENDIX A
APPENDIX A FORMS A PART OF SMD 5962-99617

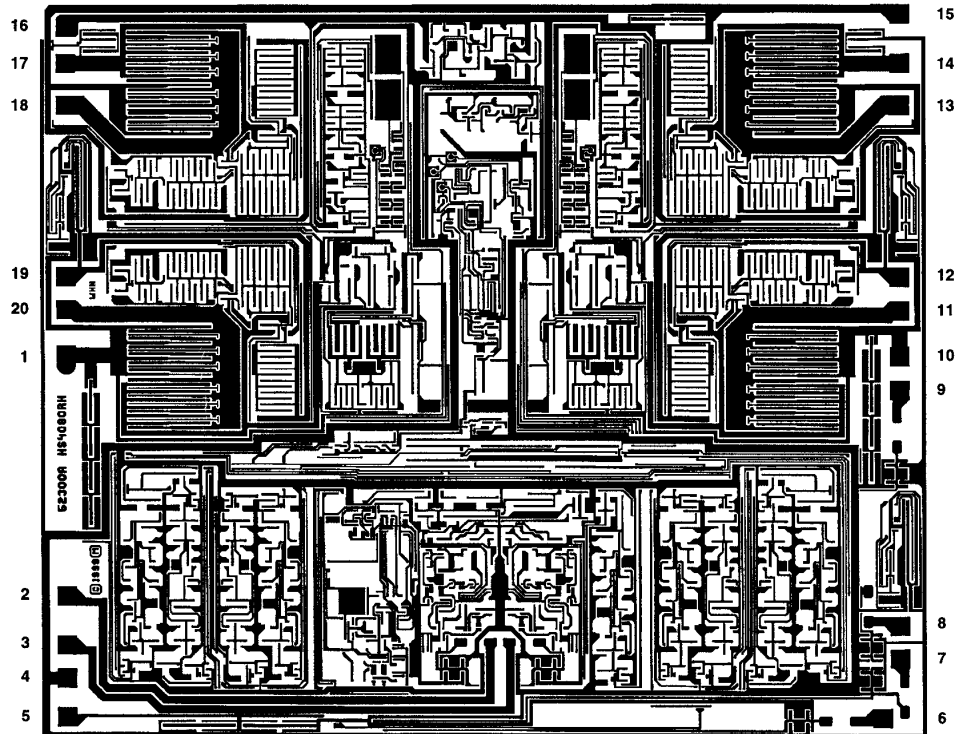

Die bonding pad locations and electrical functions

NOTE: Pad numbers reflect terminal numbers when placed in case outline S (see figure 1).

Die physical dimensions.

Die size: 4760 X 5660 microns.

Die thickness: 19 ± 1 mils.

Interface materials.

Top metallization: Al Si Cu 16.0 kÅ ± 2.0 kÅ

Backside metallization: Silicon.

Glassivation.

Type: PSG

Thickness: 8.0 kÅ ± 1.0 kÅ.

Substrate: Dielectrically Isolated (DI).

Assembly related information.

Substrate potential: Insulator.

Special assembly instructions: None

FIGURE A-1. Die bonding pad locations and electrical functions.

STANDARD MICROCIRCUIT DRAWING DEFENSE SUPPLY CENTER COLUMBUS COLUMBUS, OHIO 43216-5000	SIZE A		5962-99617
		REVISION LEVEL B	SHEET 26

STANDARD MICROCIRCUIT DRAWING BULLETIN

DATE: 02-08-30

Approved sources of supply for SMD 5962-99617 are listed below for immediate acquisition information only and shall be added to MIL-HDBK-103 and QML-38535 during the next revision. MIL-HDBK-103 and QML-38535 will be revised to include the addition or deletion of sources. The vendors listed below have agreed to this drawing and a certificate of compliance has been submitted to and accepted by DSCC-VA. This bulletin is superseded by the next dated revision of MIL-HDBK-103 and QML-38535.

Standard microcircuit drawing PIN <u>1/</u>	Vendor CAGE number	Vendor similar PIN <u>2/</u>
5962F9961701QSC	34371	HS9-4080ARH-8
5962R9961701TSC	34371	HS9-4080ARH-T
5962F9961701VSC	34371	HS9-4080ARH-Q
5962F9961701V9A	34371	HS0-4080ARH-Q

1/ The lead finish shown for each PIN representing a hermetic package is the most readily available from the manufacturer listed for that part. If the desired lead finish is not listed contact the vendor to determine its availability.

2/ Caution. Do not use this number for item acquisition. Items acquired to this number may not satisfy the performance requirements of this drawing.

Vendor CAGE
number

34371

Vendor name
and address

Intersil
2401 Palm Bay Blvd
PO Box 883
Melbourne, FL 32902-0883

The information contained herein is disseminated for convenience only and the Government assumes no liability whatsoever for any inaccuracies in the information bulletin.